



SB-85PT

BELT CONVEYOR SHIFTER

- **Net Horsepower**
238 kW (320 hp)
- **Max. Lifting Capacity**
15300 kg (33,600 lb)
- **Operating Weight**
50400 kg (111,112 lb)



SB-85PT

BELT CONVEYOR SHIFTER

- High stability and low ground pressure
- Modular power train components
- Superior traction
- Hydraulic head



ENGINE

Make and model CUMMINS KT-19C
 Type 4-cycle diesel, turbocharged, direct start, direct injection
 Gross Horsepower, SAE J1995 261 kW (350 hp)
 Net Horsepower SAE J1349/ISO 9249 238 kW (320 hp)
 Rated rpm 2100 rpm
 Maximum torque @ 1500 rpm 1530 Nm (1,128 lb-ft)
 Number of cylinders 6
 Displacement 18.8 l (1,150 in³)
 Bore and stroke 159 x 159 mm (6.25" x 6.25")
 Air cleaner dry type with exhaust aspirated, primary and safety elements and service indicator

TRANSMISSION & TORQUE CONVERTER

Countershaft type power shift, hydraulically controlled and actuated. Single stage, single phase 16" (409 mm) modular torque converter with a 2.7:1 stall ratio drives to transmission through a double universal joint.

TRAVEL SPEEDS

Gear	Range	Forward		Reverse	
		km/h	(mph)	km/h	(mph)
1st	low	2.8	(1.7)	3.4	(2.1)
	high	3.7	(2.3)	4.5	(2.8)
2nd	low	4.8	(2.9)	5.8	(3.6)
	high	5.8	(3.6)	7.0	(4.3)
3rd	low	7.1	(4.3)	8.6	(5.3)
	high	9.3	(5.7)	11.3	(7.0)

REFILL CAPACITIES

	Liter	(US gal)
Fuel tank	627	(166)
Cooling system	92	(24)
Engine lubrication, incl. filters	58	(15)
Transmission system	300	(79)
Sprocket drive, each side	77	(20)
Hydraulic system	280	(74)

STEERING & BRAKING

Unique two speed geared steering module provides gradual turns while maintaining full power to both tracks plus conventional clutch-brake performance for tight or pivot turns. This type of steering system offers superior traction in all types of operations and terrain. Coupled to 3-speed transmission and torque converter provides 6 speeds forward and 6 reverse. Complete steering module (incl. pinion and bevel gears) is removable as an assembly for superior serviceability. Hand levers, hydraulically actuate, oil cooled, adjustment free, steering planetary gears, multiple disc clutches and brakes in one control for each track. Pull back single lever to detent position for gradual turn or both levers for speed reduction. Pull lever slightly further to disengage steering clutches, fully back to brake. Single foot pedal applies both brakes for parking or down-hill speed control. Brakes are spring applied and hydraulically released.

FINAL DRIVES

Double-reduction with planetary final drive stage provides desired gear reduction at the sprocket. Three-piece bolt on sprocket distributes wear evenly over track bushings letting every tooth ride free one-half of the time to reduce wear. Sprockets are replaceable without removing track frames.

TRACK FRAME

Non-oscillating type, all-welded heavy box section track frame
 Track rollers each side 8
 Top idlers each side 2
 Front idlers (drum type) each side 1
 All rollers and idlers lifespan lubricated

TRACKS

The split master link reduces chain removal and installation time.
 Track shoe width, standard 864 mm (34")
 Track shoes each side 45
 Ground contact area w/std shoes 6.67 m² (10,336 in²)
 Ground pressure 71.3 kPa (10.2 psi)
 Grouser height 76 mm (3")
 Track adjustment full hydraulic
 Ground clearance 660 mm (26")
 Fixed drawbar - height from ground to centerline of 95 mm (3.75") clevis 719 mm (28.3")

OPERATING WEIGHT

Includes std. equipment and full fuel 50400 kg (111,112 lb)

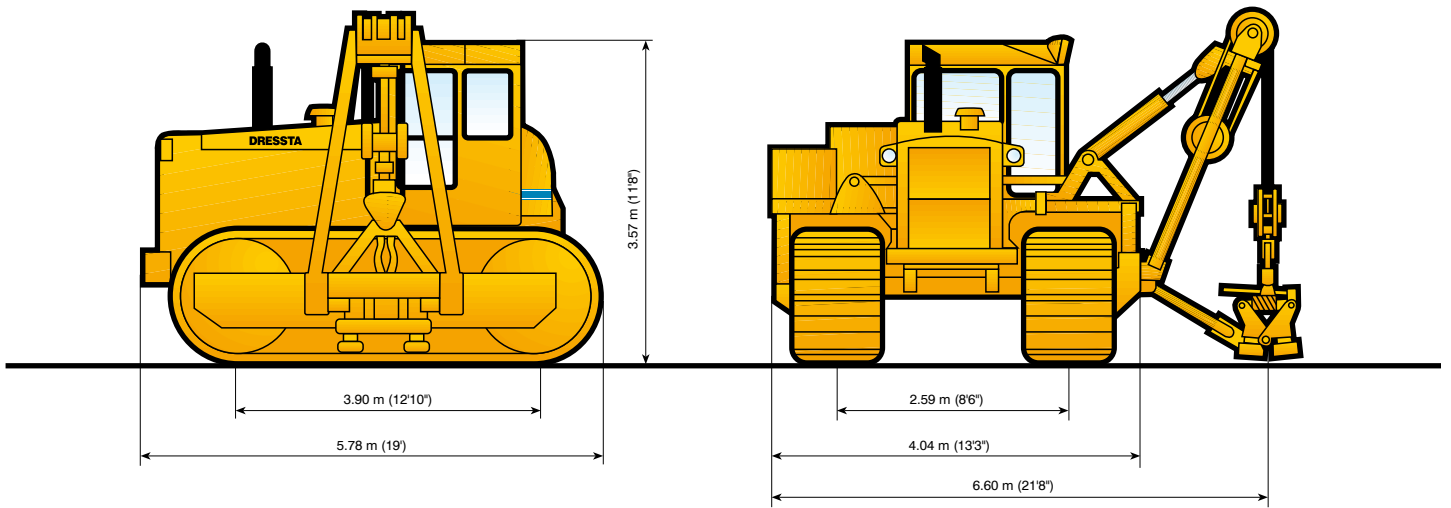

VERTICAL DIMENSIONS INCLUDE 76 mm (3") GROUSER HEIGHT

MACHINE DIMENSIONS WITH MOVING EQUIPMENT

Max. width, low position	6.60 m (21'8")
Max. width for travel	5.80 m (19')
Overall length	5.78 m (19')
Height, low position	3.60 m (11'10")
Height for travel	4.41 m (14'6")
Shipping width w/o equipment	4.04 m (13'3")

MOVING EQUIPMENT

Max. lifting capacity	15 300 kg (33,600 lb)
Frame	"A" Type, closed box fabricated
Hoisting	full hydraulic
Head dimensions	1490x835x1130 mm (59"x33"x44")
Head pulley diameters	310/340 mm (12.2"/13.4")
Max. vertical/horizontal shift	1420/500 mm (56"/19.7")
Equipment weight	11 000 kg (24,250 lb)

The moving equipment has been designed to shift belt conveyors of belt width up to 2500 mm as well as railway tracks.

It's equipped with a hydraulic head for working with rails S49, S54, S60, P65 and UIC 60. This highly specialized machine is ideal for confined areas and tough operating conditions.



SB-85PT

BELT CONVEYOR SHIFTER



STANDARD EQUIPMENT

- Air cleaner, dry type with exhaust aspirated primary and safety elements and service indicator
- Alternator, 50 A
- Antifreeze, -37°C (-34°F)
- Batteries, (4) 12 V, 1630 CCA, maintenance free
- Belt conveyor shifter equipment complete
- Bumper front
- Cab, isolation mounted, full vision, enclosed type with safety glasses and lockable door, dome light, door window wiper, emergency exit window and heater/pressurizer/defroster
- Coolant filter conditioner
- Counterweight, fixed
- Decelerator, foot operated
- Drawbar, fixed
- Exhaust pipe extension
- Fan, reversible
- Filters, oil, full flow and by-pass with replaceable elements
- Filters, transmission, hydraulic and fuel system
- Fuel strainer
- Guards: crankcase, fan, radiator, transmission
- Heat exchanger, engine oil
- Horn, electric
- Hourmeter, electric
- Instrument panel light
- Instruments, grouped in resilient - mounted panel
- Lights w/guards, 2 front on tractor, 1 rear
- Muffler
- Radiator, isolation mounted
- Seat, suspension type with arm rests
- Starting, 24 V
- Steering, planetary type, 2 speed
- Tools compartment
- Torque converter, single stage
- Track adjusters, hydraulic
- Track chain guides, integral
- Track chain sealed with split master link, 45 links
- Track frame, 8 roller, 2.59 m (102") gauge, non-oscillating type, lifespan lubricated rollers & idlers
- Track shoes, 864 mm (34"), severe service
- Transmission, power shift, 3 speeds forward, 3 reverse combined with 2 speed steering provides 6 speeds forward and 6 reverse
- Water separator, fuel system

OPTIONAL ATTACHMENTS

- Air conditioner (roof mounted) and heater/pressurizer/defroster (cab side wall mounted)
- Alarm, back-up
- Batteries (6), 12 V, 2445 CCA, cold start
- Ether start
- Flash beacon light
- Fuel pump, manually operated, fuel tank mounted
- Guards:
 - Track roller
 - Track roller, segmented
 - Sprocket dirt/rock deflector
- Lights, 2 rear, cab mounted
- Lubricated track system
- Mirror, interior and sunshield
- Mirrors, exterior, RH and LH
- Tools in metal box
- Track shoes 1016 mm (40"), clipped corner, severe service
- Vandalism protection

Specifications subject to change without notice. Illustrations and pictures may include optional equipment and may not include all standard equipment.

DRESSTA co.Ltd.

Kwiatkowskiego 1, 37-450 Stalowa Wola, P O L A N D
tel: +48 15 813 5252, 813 4556 fax: +48 15 844 4714
www.dressta.com.pl