



TD-9M

CRAWLER DOZER
STD & LGP

- **Net Horsepower**
69 kW (93 hp)
- **Blade Capacity**
1.87 m³ and 1.76 m³
(2.45 yd³ and 2.30 yd³)
- **Operating Weight**
8714 kg (19,210 lb) STD
8890 kg (19,600 lb) LGP



TD-9M

STD & LGP

- Full power shift transmission
- Highly efficient torque converter
- Wet-type steering clutches and brakes

- Lubricated track system
- Hydraulic lift, tilt & angle blade
- Left joystick for transmission and steering control

ENGINE

* Make and model	CUMMINS B4.5
Type	4-cycle diesel turbocharged, direct start, direct injection
** Gross Horsepower @ 2200 rpm	74 kW (99 hp)
*** Net Flywheel power @ 2200 rpm	69 kW (93 hp)
Maximum torque @1500 rpm	414 Nm (305 ft lb)
Number of cylinders	4
Displacement	4.5 l (275 in ³)
Bore and stroke	102 x 137.7 mm (4.02" x 5.42")
Lubrication, full flow filtering.....	full pressure
Number of main bearings	5
Electrical system	12 V
Air cleaner	two stage, dry type with service indicator

* Meets EU Stage II and EPA Tier 2 emission regulations
 ** Output of complete engine operating under SAE J1995 conditions
 *** Flywheel power-output of standard engine complete with fan, air cleaner, alternator (not charging), water pump, lubricating oil pump and fuel pump, per SAE J1349

TRANSMISSION & TORQUE CONVERTER

Modular countershaft type full power shift, electro-hydraulically actuated with 3 speeds forward, 3 reverse. Joystick control valve has electric transmission range shift control for up and down shifting. Single stage 280 mm (11") torque converter with 2.0:1 stall ratio drives to transmission through a permanently lubricated double universal joint.

TRAVEL SPEEDS

Gear	Forward		Reverse	
	km/h	(mph)	km/h	(mph)
1 st	3.3	(2.0)	3.9	(2.4)
2 nd	5.4	(3.3)	6.3	(3.9)
3 rd	8.9	(5.5)	10.5	(6.5)

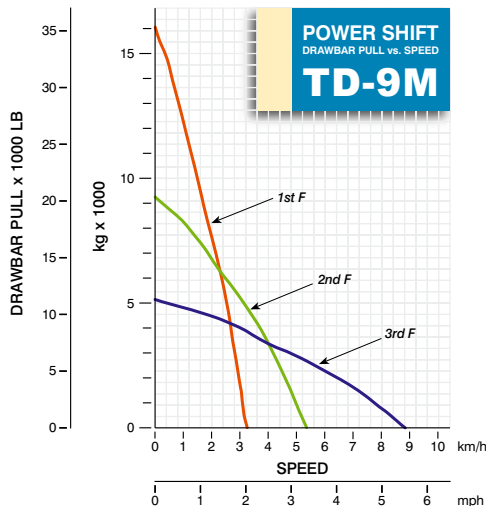

STEERING & BRAKING

Single stage planetary type, wet single disc steering clutches. Single disc, wet-type steering brakes. Steering clutches and brakes run in oil and are hydraulically actuated. The left hand joystick controls transmission and steering drive. Right foot pedal applies decelerator, center pedal applies disc brakes for downhill speed control and parking. Brakes are spring applied and hydraulically released. Parking brake is also applied by safety lever.

FINAL DRIVES

Single stage spur-gear drive to sprockets 8.1:1 reduction ratio. Final drive has metal face seals. Operates in oil for long life. Sprockets are replaceable without removing track frames.

TRACK FRAME

Heavy steel box section, rigid mount.

	STD	LGP
Track rollers each side	6	6
Top idlers each side	1	1
Front idlers (disc type)	casting	casting
All rollers and idlers	lifespan lubricated	

TRACKS

Lubricated Track System virtually eliminates internal pin and bushing wear.

	STD	LGP
Track shoe width	457 mm (18")	610 mm (24")
Track shoes, each side	39	39
Ground contact area	1.99 m ² (3,096 in ²)	2.66 m ² (4,128 in ²)
Ground pressure	42.5 kPa (6.17 psi)	32.5 kPa (4.72 psi)
Strutted track link pitch	165 mm (6.5")	
Height of grouser	53.6 mm (2.11")	
Track adjustment	full hydraulic	
Minimum ground clearance		
from bottom face of shoe	381 mm (15")	
Recovery hitch-height		
from ground to centerline of clevis	536 mm (21.1")	

REFILL CAPACITIES

	Liter	(US gal)
Fuel tank	170	(45)
Cooling system	24.9	(6.6)
Crankcase	10.4	(2.7)
Transmission & steering drive	70	(18.5)
Final drive, each side	15.1	(4.0)

OPERATING WEIGHT

Includes ROPS, hydraulic angle blade, standard equipment and full fuel.	
STD	8714 kg (19,210 lb)
LGP	8890 kg (19,600 lb)

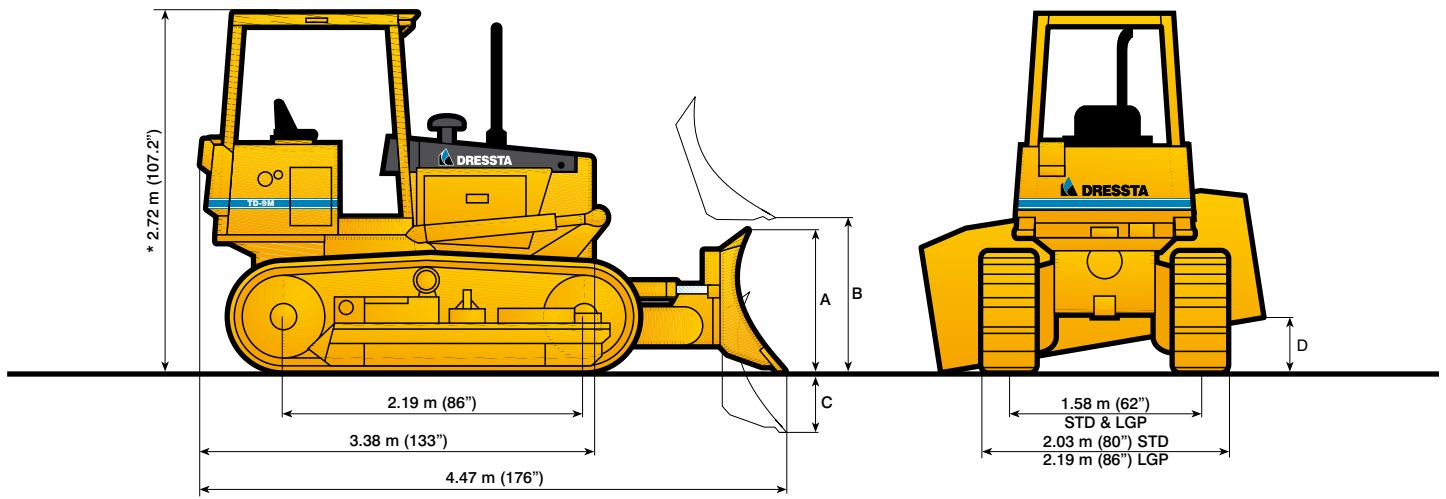

* Dimension includes 53.6 mm (2.11") grouser height
 Overall height with Cab ROPS – 2.76 m (108.5")

OVERALL DIMENSIONS WITH EQUIPMENT

Type of Track Frame	STD	LGP
Length, with blade and drawbar	4.80 m (15'9")	4.80 m (15'9")
Width, blade angled	2.44 m (8'0")	2.57 m (8'5")
Width, blade straight	2.69 m (8'10")	2.82 m (9'3")

BLADE SPECIFICATIONS

Type of Track Frame	STD	LGP
Blade capacity, SAE J1265	1.87 m ³ (2.45 yd ³)	1.76 m ³ (2.30 yd ³)
Max. usable track shoe width	508 mm (20")	610 mm (24")
Blade dimensions:		
– width over end bits	2.69 m (8'10")	2.82 m (9'3")
– height, struts centered A	0.99 m (3'3")	0.95 m (3'1")
Max. lift, straight B	0.87 m (34.3")	0.87 m (34.3")
Max. drop below ground level C	0.42 m (16.5")	0.42 m (16.5")
Max. tilt adjustment D	0.40 m (15.7")	0.42 m (16.4")
Blade angle, either side	25°	25°

RIPPER SPECIFICATION

Type	Multi-Shank		
Tool Beam		Shanks	
Overall width	1.44 m (4'9")	Number of shanks per ripper, max.	5
Cross section, height x width.....	165 x 165 mm (6.5" x 6.5")	Spacing center to center	343 mm (13.5")
Ground clearance under tool beam	716 mm (28.2")	Penetration, max.	305 mm (12.0")
Weight		Ground clearance, max. raised	422 mm (16.6")
Complete, including three shanks	510 kg (1,120 lb)	Shank positions (vertical).....	2
Each additional shank	9 kg (20 lb)		

HYDRAULIC CONTROL SYSTEM

Pump, tandem gear.		Cylinders, bore and stroke	
Output @ 3.45 MPa (500 psi)		Lift (2)	89 x 449 mm (3.5" x 17.7")
& rated engine rpm	69.6 l/min (18.4 gpm)	Angle (2).....	89 x 352 mm (3.5" x 13.9")
Relief valve setting		Tilt (1)	89 x 144 mm (3.5" x 5.7")
Blade lift & ripper	15 512 kPa (2,250 psi)	Reservoir with sight gauge, system capacity, right fender mounted,	
Tilt.....	15 512 kPa (2,250 psi)	includes cylinders & lines	51 l (13.5 gal)

STANDARD EQUIPMENT

- Air cleaner, dry type, with primary and safety elements and service indicator
- Alarm, back-up, 2 level sound
- Alternator, 105 A
- Antifreeze, -37°C (-34°F)
- Battery, (1) 12 V, 815 CCA, maintenance free
- Canopy ROPS (SAE J1040) with roof extension, roof headliner, mirror
- Cooling module; includes radiator and transmission oil cooler (side-by-side); isolation mounted
- Counterweights, front idler
- Cup holder
- Decelerator – right pedal and brake – left pedal with safety lock, foot operated
- Engine hood, solid
- Engine side doors, perforated
- Fan, blower
- Filters, with "spin-on" elements: engine oil, fuel, power train, equip. hyd.
- Guards: crankcase with pull hook, instrument panel, lights, radiator, transmission, rock deflector, fan, fuel tank bottom and back-up alarm
- Hitch, retrieval
- Horn
- Hydraulics, 3-spool valve, "T" control
- Instruments:
 - Gauges: hourmeter, coolant temperature, engine oil pressure, power train oil temperature, voltmeter, fuel
- Warning lights: transmission filter service indicator, air filter and hydraulic filter service indicator
- Lights, 2 front, 1 rear, halogen type
- Muffler, underhood with exhaust pipe and elbow
- Power train diagnostic check panel w/brake release port
- Protection guard for fuel tank and filler
- Radiator guard door, louvered
- Seat belt (SAE J386) – 3" wide, retractable
- Seat, suspension type with adjustable arm rests
- Starting aid – air grid heater
- Starting, 12 V
- Steering & transmission, left hand single lever control, joystick w/safety lever
- Strainer, fuel
- Throttle control, L.H. location
- Tools compartment
- Torque converter, single stage
- Track adjusters, hydraulic
- Track chains, sealed & lubricated (LTS) with split master links, 39 links
- Track frame, 6 rollers, 1.58 m (62") gauge, rigid type, lifespan lubricated rollers and idlers, front and rear chain guides
- Track shoes, 457 mm (18")
- Transmission, full power shift, 3 speeds forward, 3 reverse
- Water separator, fuel system

OPTIONAL ATTACHMENTS

- Air conditioner/heater/pressurizer/defroster
- Angle dozer 1.87 cu.m (2.45 cu.yd), standard width, inside arm w/hyd. tilt & angle
- Angle dozer 1.76 cu.m (2.30 cu.yd) wide, inside arm w/hyd. tilt & angle
- Battery, cold start, 12 V, 960 CCA
- Cab, ROPS with sound suppression, wipers (4) and washers, mirror, dome light & tinted safety glass
- Defroster fan (for use w/cab)
- Exhaust pipe, forestry (for use w/sweeps)
- Fan, reversible
- Guards:
 - track roller, std. strength
 - track roller, full length, heavy duty type
- Heater/pressurizer/defroster
- Hood, perforated (blower fan recommended)
- Hydraulics, 4-spool valve w/2 levers ("T" + single), for use w/ripper or auxiliary attachments
- Limb risers, straight (not for use w/cab)
- Mirrors, 2 pcs (for use w/cab)
- Resonator, exhaust
- Ripper, multi-shank w/3 teeth (provision for 5 teeth)
- Screening package, black painted (Canopy ROPS for screens installation must be ordered)
 - screens, front
 - screen, rear
 - doors and side screens w/third post
 - screen, overhead, for upper front lights protection
- Sweeps, front (not for use w/cab)
- Track shoes:
 - 457 mm (18") w/mud relief
 - 508 mm (20")
 - 610 mm (24")
- Vandalism protection

Specifications subject to change without notice. Illustrations may include optional attachments and accessories and may not include all standard equipment.

NOTE: Low Ground Pressure (LGP) tractors are designed for use in mud, snow and other soft ground applications.

Use in hard or rocky conditions will reduce undercarriage life and can cause damage to components.

DRESSTA co.Ltd.

Kwiatkowskiego 1, 37-450 Stalowa Wola, P O L A N D
 tel: +48 15 813 5252, 813 4556 fax: +48 15 844 4714
 www.dressta.com.pl