



TD-7M

CRAWLER DOZER
STD-LT-LGP



■ **Net Horsepower**
55 kW (74 hp)

■ **Blade Capacity**
1.40 m³ and 1.45 m³
(1.81 yd³ and 1.90 yd³)

■ **Operating Weight**
7348 kg (16,200 lb) STD
7697 kg (16,970 lb) LT
7997 kg (17,630 lb) LGP

TD-7M

STD-LT-LGP

- Full power shift transmission
- Highly efficient torque converter
- Wet-type steering clutches and brake
- Lubricated track system
- Hydraulic lift, tilt & angle blade
- Left joystick for transmission and steering control



ENGINE

* Make and model	CUMMINS B4.5
Type	4-cycle diesel, naturally aspirated, direct start, direct injection
** Gross Horsepower @ 2500 rpm	60 kW (80 hp)
*** Net Flywheel power @ 2500 rpm	55 kW (74 hp)
Maximum torque @1300 rpm	301 Nm (222 ft lb)
Number of cylinders	4
Displacement	4.5 l (275 in ³)
Bore and stroke	102 x 137.7 mm (4.02" x 5.42")
Lubrication, full flow filtering	full pressure
Number of main bearings	5
Electrical system	12 V
Air cleaner	two stage, dry type with service indicator

* Meets EU Stage II and EPA Tier 2 emission regulations
 ** Output of complete engine operating under SAE J1995 conditions
 *** Flywheel power-output of standard engine complete with fan, air cleaner, alternator (not charging), water pump, lubricating oil pump and fuel pump, per SAE J1349

TRANSMISSION & TORQUE CONVERTER

Modular countershaft type full power shift, electro-hydraulically actuated with 3 speeds forward, 3 reverse. Joystick control valve has electric transmission range shift control for up and down shifting. Single stage 280 mm (11") torque converter with 2.16:1 stall ratio drives to transmission through a permanently lubricated double universal joint.

TRAVEL SPEEDS

Gear	Forward		Reverse	
	km/h	(mph)	km/h	(mph)
1 st	3.4	(2.1)	4.0	(2.5)
2 nd	5.6	(3.5)	6.6	(4.1)
3 rd	9.2	(5.7)	10.8	(6.7)

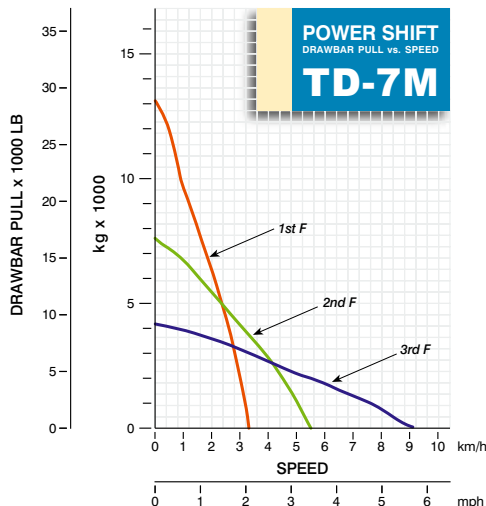

STEERING & BRAKING

Single stage planetary type, wet single disc steering clutches. Single disc, wet-type steering brakes. Steering clutches and brakes run in oil and are hydraulically actuated. Right foot pedal applies decelerator, center pedal applies disc brakes for downhill speed control and parking. Brakes are spring applied and hydraulically released. Parking brake is also applied by safety lever.

FINAL DRIVES

Single stage spur-gear drive to sprockets 5.66:1 reduction ratio. Final drive has metal face seals. Operates in oil for long life. Sprockets are replaceable without removing track frames.

TRACK FRAME

Heavy steel channel, rigid mount.

	STD	LT	LGP
Track rollers each side	5	6	6
Top idlers each side	1	1	1
Front idlers (disc type)		casting	
All rollers and idlers	lifespan lubricated		

TRACKS

	STD	LT	LGP
Track shoe width	381 mm (15")	381 mm (15")	610 mm (24")
Track shoes, each side	34	37	37
Ground contact area	1.4 m ² (2,160 in ²)	1.59 m ² (2,460 in ²)	2.54 m ² (3,936 in ²)
Ground pressure	51 kPa (7.45 psi)	47 kPa (6.86 psi)	31 kPa (4.45 psi)
Strutted track link pitch	165 mm (6.5")		
Height of grouser	53.6 mm (2.11")		
Track adjustment	full hydraulic		
Minimum ground clearance from bottom face of shoe	323 mm (12.7")		
Recovery hitch-height from ground to centerline of clevis	477 mm (18.8")		

REFILL CAPACITIES

	Liter	(US gal)
Fuel tank	170	(45)
Cooling system	24.9	(6.6)
Crankcase	10.4	(2.7)
Transmission & steering drive	70	(18.5)
Final drive, each side	9.5	(2.5)

OPERATING WEIGHT

Includes ROPS, hydraulic angle blade, standard equipment and full fuel.

STD	7348 kg (16,200 lb)
LT	7697 kg (16,970 lb)
LGP	7997 kg (17,630 lb)

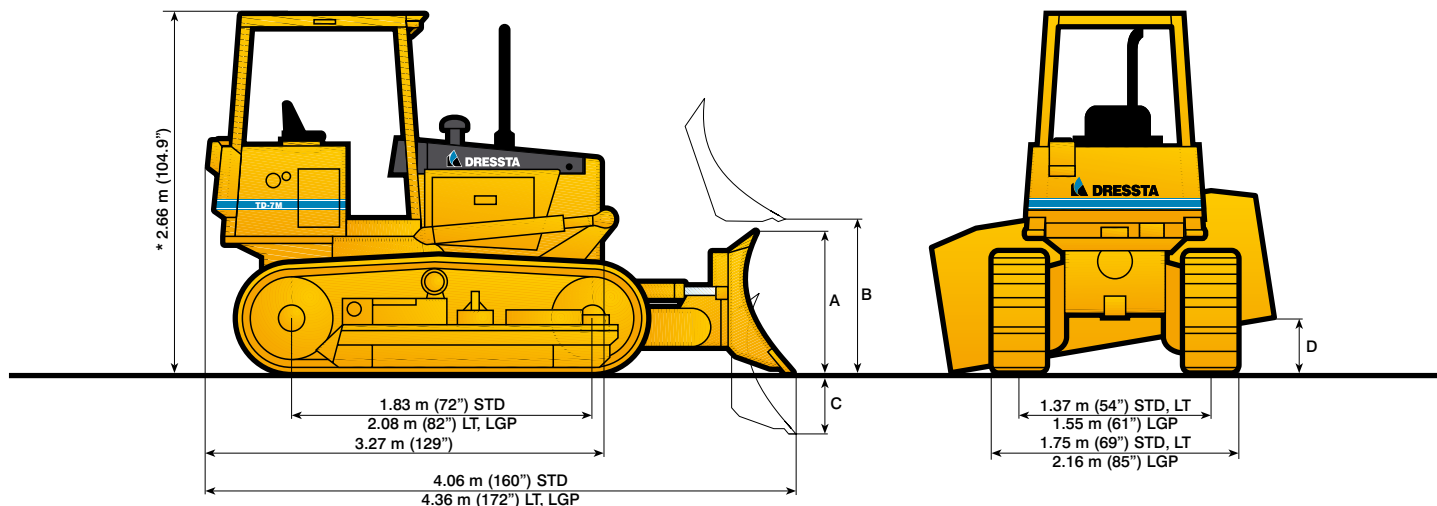

* Dimension includes 53.6 mm (2.11") grouser height
 Overall height with Cab ROPS = 2.70 m (106.2")

OVERALL DIMENSIONS WITH EQUIPMENT

Type of Track Frame	STD	LT	LGP
Length, with blade and drawbar	4.50 m (14'9")	4.78 m (15'8")	4.78 m (15'8")
Width, blade angled	2.39 m (7'10")	2.39 m (7'10")	2.57 m (8'5")
Width, blade straight	2.62 m (8'7")	2.62 m (8'7")	2.82 m (9'3")

BLADE SPECIFICATIONS

Type of Track Frame	STD	LT	LGP
Blade capacity, SAE J1265	1.4 m ³ (1.81 yd ³)	1.4 m ³ (1.81 yd ³)	1.45 m ³ (1.90 yd ³)
Max. usable track shoe width	432 mm (17")	432 mm (17")	610 mm (24")
Blade dimensions:			
– width over end bits	2.62 m (8'7")	2.62 m (8'7")	2.82 m (9'3")
– height, struts centered	A	0.84 m (2'9")	0.84 m (2'9")
Max. lift, straight	B	0.94 m (37")	0.89 m (35")
Max. drop below ground level	C	0.45 m (17.7")	0.44 m (17.3")
Max. tilt adjustment	D	0.39 m (15.2")	0.39 m (15.2")
Blade angle, either side	25°	25°	25°

RIPPER SPECIFICATION

Type	Multi-Shank	
Tool Beam		Shanks
Overall width	1.40 m (4'7")	Number of shanks per ripper, max.
Cross section, height x width	152 x 152 mm (6.0" x 6.0")	Spacing center to center
Ground clearance under tool beam	696 mm (27.4")	Penetration, max.
Weight		Ground clearance, max. raised
Complete, including three shanks	430 kg (950 lb)	Shank positions (vertical)
Each additional shank	9 kg (20 lb)	

HYDRAULIC CONTROL SYSTEM

Pump, tandem gear.		Cylinders, bore and stroke
Output @ 3.45 MPa (500 psi)		Lift (2)
& rated engine rpm	75.2 l/min (19.9 gpm)	Angle (2)
Relief valve setting		Tilt (1)
Blade lift & ripper	15 512 kPa (2,250 psi)	Reservoir with sight gauge, system capacity, right fender mounted,
Tilt	15 512 kPa (2,250 psi)	includes cylinders & lines

STANDARD EQUIPMENT

- Air cleaner, dry type, with primary and safety elements and service indicator
- Alarm, back-up, 2 level sound
- Alternator, 105 A
- Antifreeze, -37°C (-34°F)
- Battery, (1) 12 V, 815 CCA, maintenance free
- Canopy ROPS (SAE J1040) with roof extension, roof headliner, mirror
- Cooling module; includes radiator and transmission oil cooler (side-by-side); isolation mounted
- Decelerator – right pedal and brake – left pedal with safety lock, foot operated
- Engine hood, solid
- Engine side doors, perforated
- Fan, blower
- Filters, with "spin-on" elements, engine oil, fuel, power train, equipment hydraulic
- Guards: crankcase with pull hook, instrument panel, lights, radiator, transmission, rock deflector, fan, fuel tank bottom and back-up alarm
- Hitch, retrieval
- Horn
- Hydraulics, 3-spool valve, "T" control
- Instruments:
 - Gauges: hourmeter, coolant temperature, engine oil pressure, power train oil temperature, voltmeter, fuel
 - Warning lights: transmission filter service indicator, air filter and hydraulic filter service indicator
- Lights, 2 front, 1 rear, halogen type
- Muffler, underhood with exhaust pipe and elbow
- Power train diagnostic check panel w/brake release port
- Protection guard for fuel tank and filler
- Radiator guard door, louvered
- Seat belt (SAE J386) – 3" wide, retractable
- Seat, suspension type with adjustable arm rests
- Starting aid – air grid heater
- Starting, 12 V
- Steering & transmission, left hand single lever control, joystick w/safety lever
- Strainer, fuel
- Throttle control, L.H. location
- Tools compartment
- Torque converter, single stage
- Track adjusters, hydraulic
- Track chains, sealed & lubricated (LTS) with split master links, 37 links
- Track frame, 5 rollers, 1.37 m (54") gauge, rigid type, lifespan lubricated rollers and idlers, front and rear chain guides
- Track frame covers
- Track shoes, 381 mm (15")
- Transmission, full power shift, 3 speeds forward, 3 reverse
- Water separator, fuel system

OPTIONAL ATTACHMENTS

- Air conditioner/heater/pressurizer/defroster
- Angle dozer 1.40 cu.m (1.81 cu.yd), inside arm w/hyd. tilt & angle, for STD
- Angle dozer 1.40 cu.m (1.81 cu.yd), inside arm w/hyd. tilt & angle, for LT
- Angle dozer, wide, 1.45 cu.m (1.90 cu.yd), inside arm w/hyd. tilt & angle, for LGP
- Battery, cold start, 12 V, 960 CCA
- Counterweights, front idler
- Cab, ROPS with sound suppression, wipers (4) and washers, mirror, dome light & tinted safety glass
- Defroster fan (for use w/cab)
- Exhaust pipe, forestry (for use w/sweeps)
- Fan, reversible
- Guards
 - track roller, standard strength
 - track roller, full length, heavy duty type
- Heater/pressurizer/defroster
- Hood, perforated (blower fan recommended)
- Hydraulics, 4-spool valve w/2 levers ("T" + single), for use w/ripper or auxiliary attachments
- Limb risers, straight (not for use w/cab)
- Lubricated track system, 37 links, for LT and LGP
- Mirrors, 2 pcs, (for use w/cab)
- Resonator, exhaust
- Ripper, multi-shank w/3 teeth (provision for 5 teeth)
- Screening package, black painted
 - (Canopy ROPS for screens installation must be ordered)
 - screens, front
 - screen, rear
 - doors and side screens w/third post
 - screen, overhead, for upper front lights protection
- Sealed track system, 34 links, for STD
- Sweeps, front (not for use w/cab)
- Track frame for LT applications, 6 rollers, 1.37 m (54") gauge, rigid type
- Track frame for LGP applications, 6 rollers, 1.55 m (61") gauge, rigid type
- Track frame covers, LT
- Track frame covers, LGP
- Track shoes, set of 68, for STD
 - 381 mm (15") w/mud relief
 - 432 mm (17")
- Track shoes, set of 74, for LT
 - 381 mm (15")
 - 381 mm (15") w/mud relief
 - 432 mm (17")
- Track shoes, set of 74, for LGP
 - 610 mm (24")
- Vandalism protection

Specifications subject to change without notice. Illustrations may include optional attachments and accessories and may not include all standard equipment.

NOTE: Low Ground Pressure (LGP) tractors are designed for use in mud, snow and other soft ground applications.

Use in hard or rocky conditions will reduce undercarriage life and can cause damage to components.

DRESSTA co.Ltd.

Kwiatkowskiego 1, 37-450 Stalowa Wola, P O L A N D
 tel.: +48 15 813 5252, 813 4556 fax: +48 15 844 4714
 www.dressta.com.pl