

macchine edili ed agricole
d DIECI

Pegasus 40.17

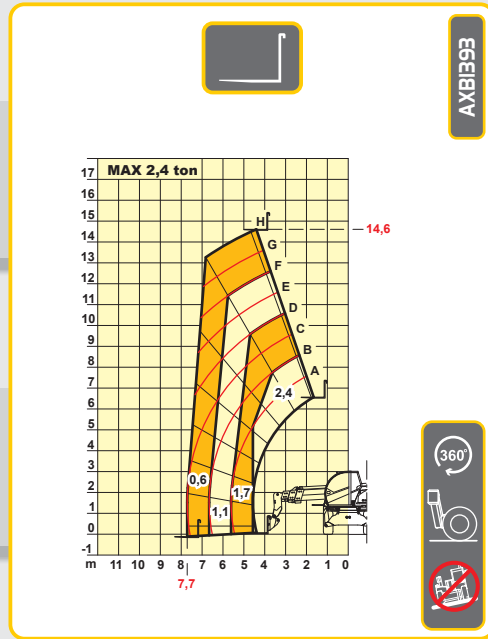

Pegasus 40.17

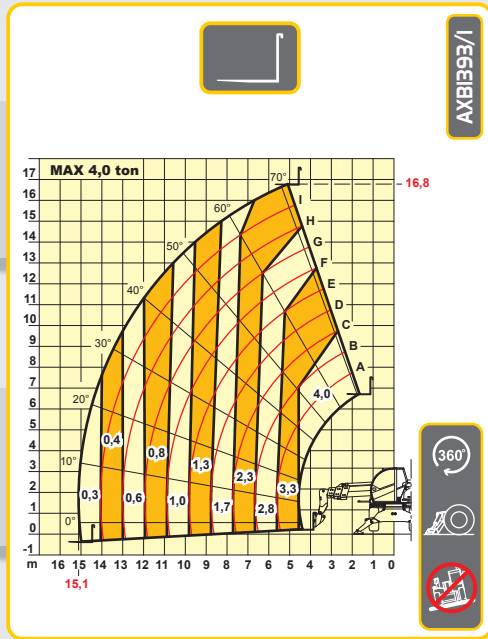
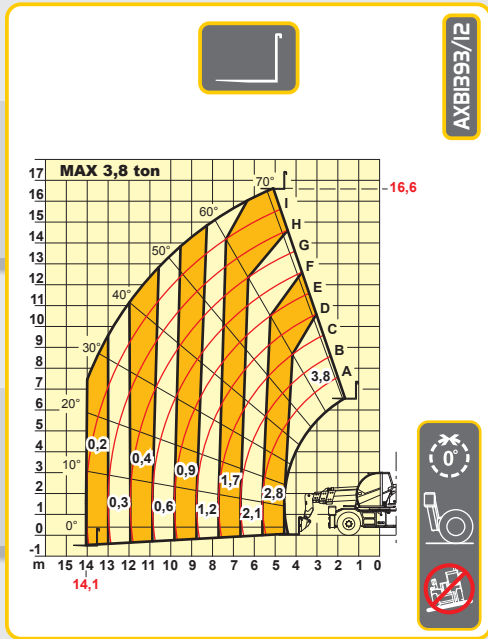

PERFORMANCES

- Maximum capacity: 4.000 kg
- Capacity at maximum height on stabilizers: 2.300 kg
- Capacity at maximum height on tyres: 1.700 kg
- Capacity at maximum boom extension on stabilizers: 300 kg
- Capacity at maximum boom extension on tyres: 200 kg
- Maximum lifting height on stabilizers: 16,80 m
- Maximum lifting height on tyres: 16,60 m
- Maximum horizontal boom extension: 15,10 m
- Boom extension at maximum height: 5,10 m
- Fork tilting angle: 134°
- Tearing force: 5.700 daN
- Towing force: 9.000 daN
- Maximum allowable slope: 40°
- Total empty weight: 15.000 kg
- Max speed (referred to wheels having the maximum allowable diameter): 40 km/h



TRANSMISSION

- Transmission: Hydrostatic with variable delivery pump
- Hydraulic engine: with automatic adjustment
- Reversing gear: Electro - hydraulic
- Inching pedal for controlled forward movement
- Servocontrolled 2 speed gearbox



HYDRAULIC SYSTEM

- Double gear pump with "Energy Saving" system
- Gear pump with capacity at max speed: 135 lt/1'
- Max working pressure: 230 bar
- Control valve with joystick: 5 in 1 proportional
- Simultaneous movements: 5
- Proportional control distributor "Load Sensing" with "Flow Sharing"



DIFFERENTIAL AXLES

- Steering axles: 2, with planetary reduction gears
- Type of steering: 4 wheels / transversal / 2 wheels
- Front axle: levelling
- Rear axle: oscillating
- Service brake: oil bath on the 4 wheels with double hydraulic system and servo brake

Negative parking brake.



ENGINE

- PERKINS 1104D-ETA - 106 kW
- Power: 106 kW (144 hp) at 2200 rpm
- Type: four-stroke engine, diesel, Common-Rail
- Cylinders number and layout: 4, vertical in line
- Displacement: 4399 cm³ -Turbo compressor aftercooler
- Cooling system: liquid
- Specific fuel consumption per hour (2.200 rpm): 230g/kWh
- Electronic accelerator.
- Manual accelerator.
- Air pre-heater for cold climates.



REFUELLING (litre)

- Hydraulic tank: 270
- Fuel tank: 180



STANDARD DEVICES

- Anti-tipping device with block for hazardous movements.
- Continuous turret rotation over 360°.
- Oscillation block on rear axle.
- Hydraulic socket for possible accessories on boom head.
- ROPS-FOPS approved closed soundproof cab with heating and opening roof.
- Stabilizers with joystick control
- Grammer deluxe seat.
- High efficiency cyclone air filter.
- Self-blocking rear axle (Limited Slip)



OPTIONAL AND ACCESSORIES

- A/C; Webasto heater; digital speedometer; water heater; pneumatic seat suspension; light on boom head; quick attachment for accessories; radio; anti-theft alarm; glass protection; transverse levelling device on wheels and others...
- (For further customised accessories, please consult your local dealer)



TYRES

- Tyres: 18x19,5" (Industrial)
- Alternative: 18x19,5" (Agricultural)

SYMBOLS KEY

| | | | | | | | |
|--------------|-------------------------------|--------------------|--------------------------|------------------------------|----------------------|---------------------|------------------------------------------------|
| | | | | | | | |
| Negative jib | Extendable three-sided basket | Jib (Measurements) | Centering handler jib | 360° Continuous rotation | 0° Front position | Stabilizers raised | Forks |
| | | | | | | | |
| Positive jib | Three-sided fixed basket | Winch (Capacity) | Fork-carrying plate hook | 400° Non-continuous rotation | Do not work on tyres | Stabilizers lowered | DO NOT maneuver if the machine is NOT levelled |

Equipment

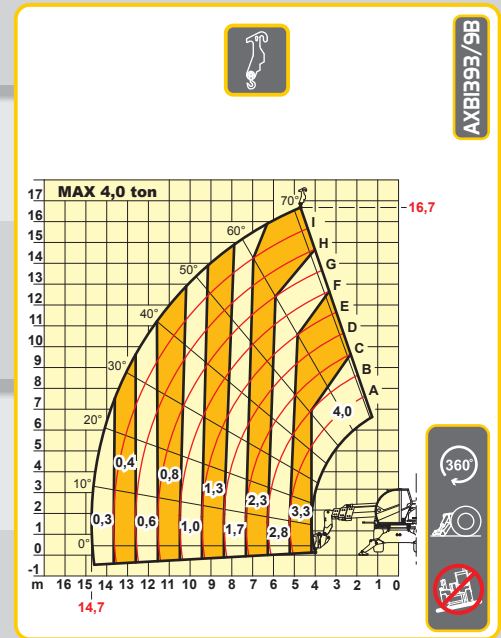
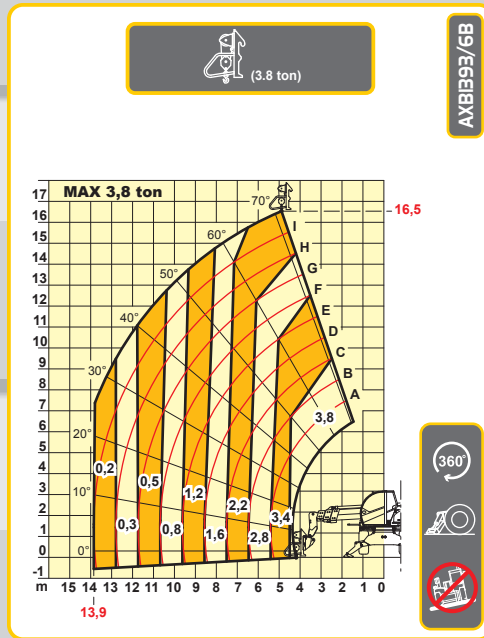
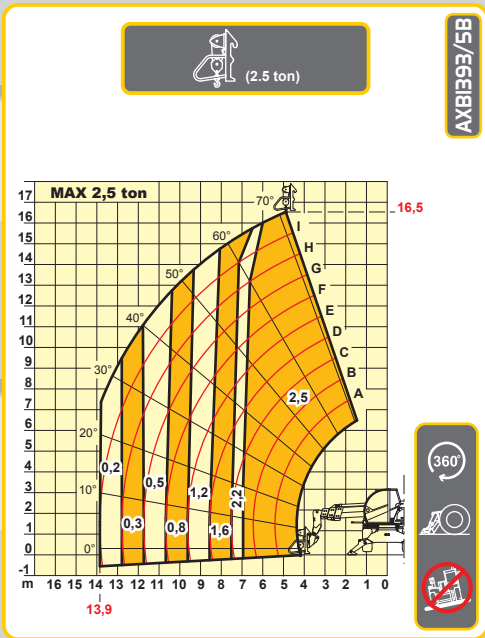
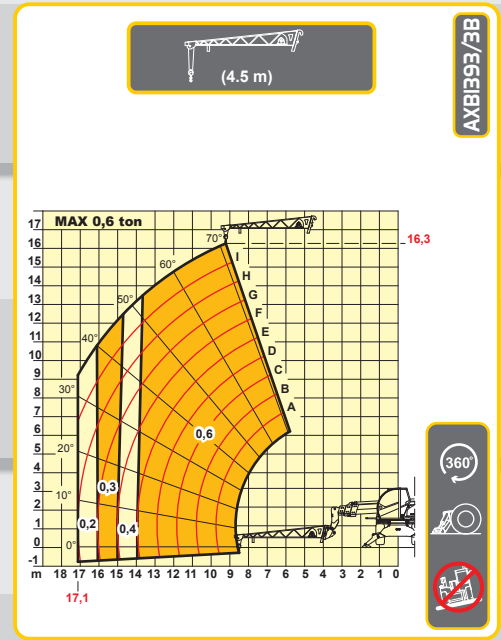
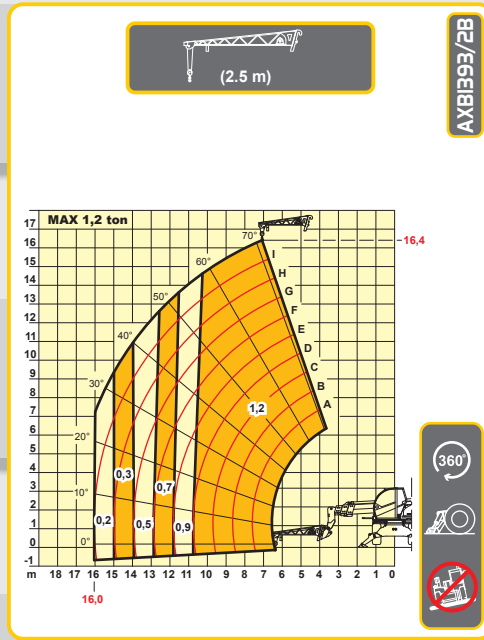
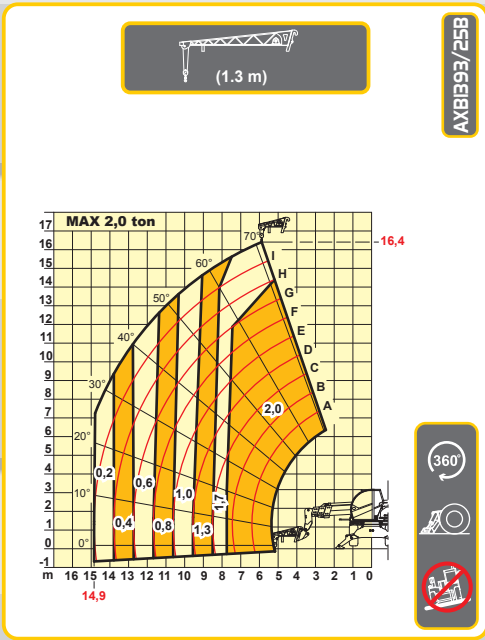
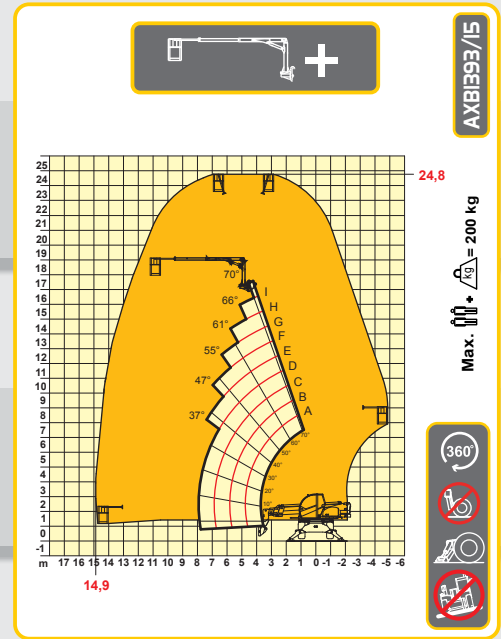
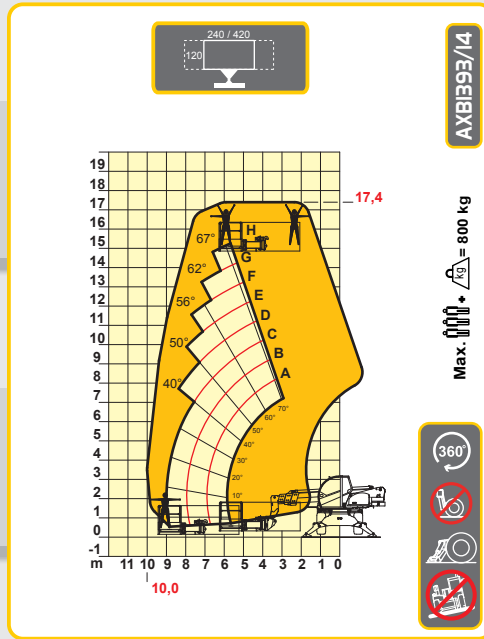
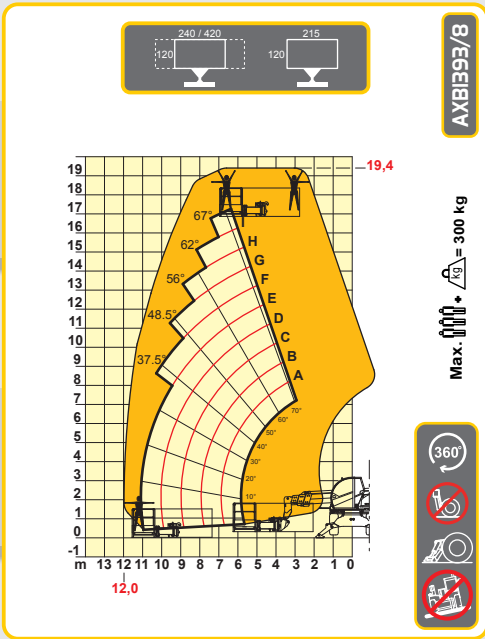

Pegasus 40.17

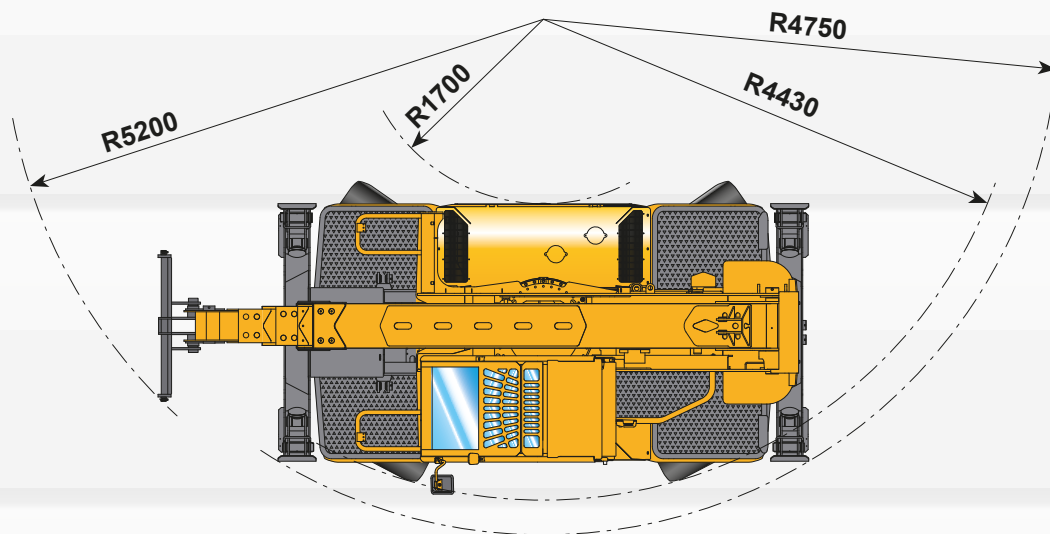
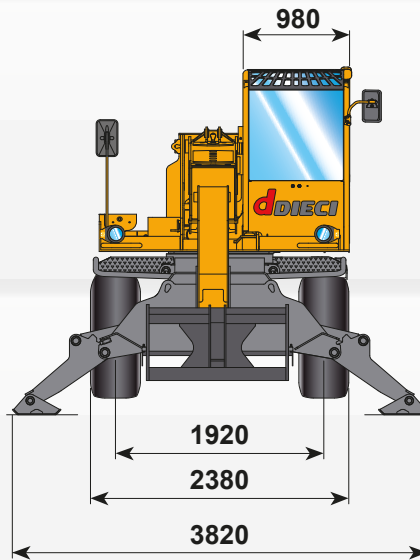
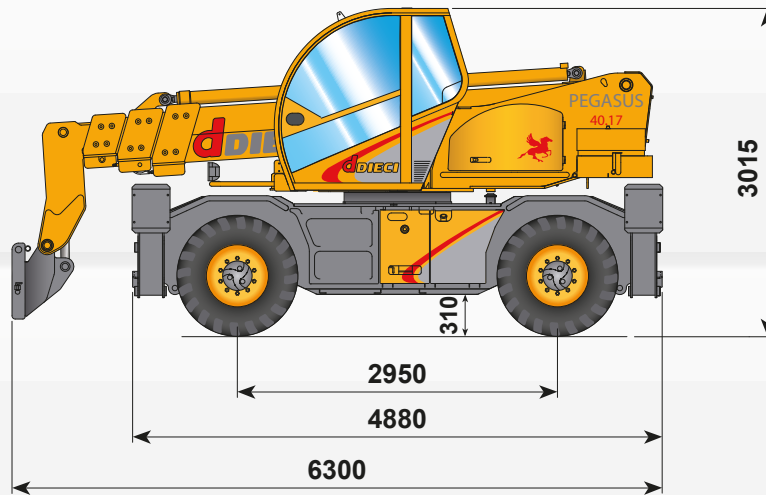

I dati contenuti in questo stampato sono forniti a titolo indicativo; i modelli descritti sono suscettibili di modifiche, senza preavviso, da parte del costruttore, disegni e fotografie possono riferirsi a equipaggiamenti opzionali o ad allestimenti destinati ad altri paesi. Per ogni altra informazione, rivolgersi alla sede DIECI all'indirizzo a fondo scheda.
The information contained in the present publication is only intended as an indication; the models described may be modified, without notice, by the manufacturer, drawings and photographs may refer to optional equipment or to particular specifications for other countries. For any further information, please contact DIECI headquarters at the address given below.