

macchine edili ed agricole
d DIECI

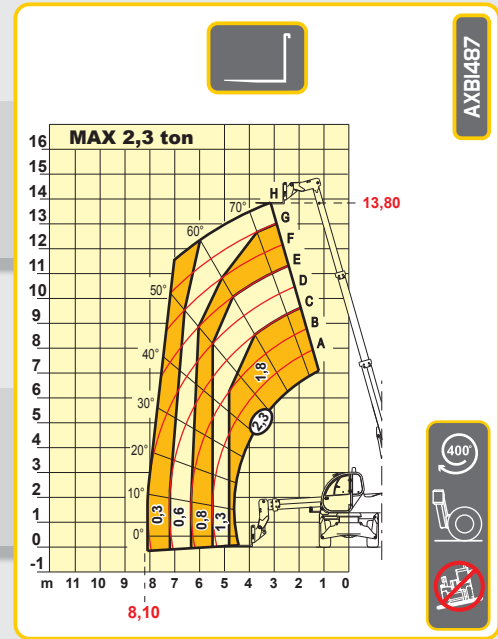

Pegasus 38.16 

Pegasus 38.16

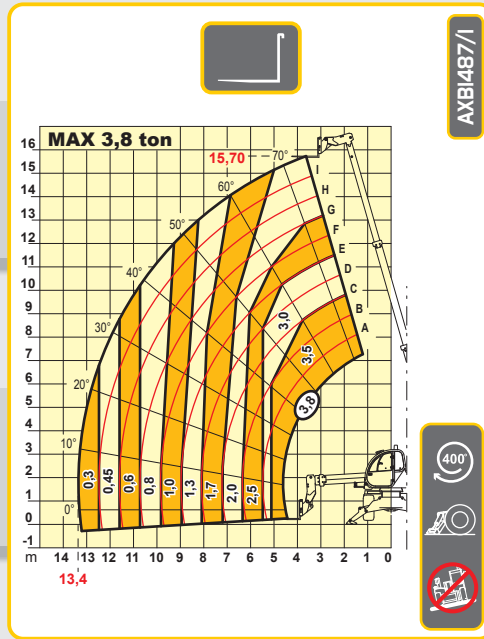
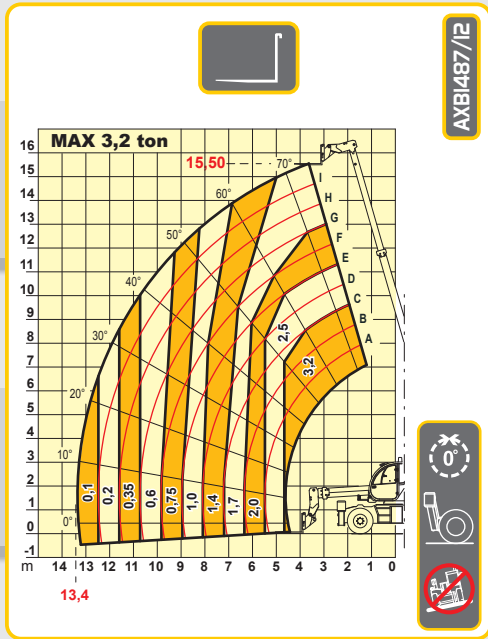

PERFORMANCES

Maximum capacity:..... 3.800 kg
 Capacity at maximum height on stabilizers:..... 2.000 kg
 Capacity at maximum height on tyres:..... 1.700 kg
 Capacity at maximum boom extension on stabilizers:..... 300 kg
 Capacity at maximum boom extension on tyres:..... 300 kg
 Maximum lifting height on stabilizers:..... 15,70 m
 Maximum lifting height on tyres:..... 13,80 m
 Maximum horizontal boom extension:..... 13,35 m
 Boom extension at maximum height:..... 3,70 m
 Fork tilting angle:..... 134°
 Tearing force:..... 5.700 daN
 Towing force:..... 7.300 daN
 Maximum allowable slope:..... 40 %
 Total empty weight:..... 13.100 kg
 Max speed (referred to wheels having the maximum allowable diameter):..... 30 km/h



TRANSMISSION

Transmission:..... Hydrostatic with variable capacity pump
 Hydraulic engine:..... with automatic adjustment
 Reversing gear:..... Electro - hydraulic
 Inching pedal for controlled forward movement
 Servocontrolled 2 speed gearbox



HYDRAULIC SYSTEM

Gear pump with capacity at max speed:..... 100 lt/1'
 Max working pressure:..... 230 bar
 Control distributor with joystick:..... 5 in 1 proportional



DIFFERENTIAL AXLES

Steering axles:..... 2, with planetary reduction gears
 Type of steering:..... 4 wheels / transversal / 2 wheels
 Front axle:..... levelling
 Rear axle:..... oscillating (can be blocked)
 Service brake:..... oil bath on the 4 wheels with double hydraulic system and servo brake
 Negative parking brake.



ENGINE

IVECO NEF - TA - 74 kW ENGINE
 Maximum power:..... 74 kW (101 hp) at 2200 rpm
 Operating principle:..... four-stroke, diesel engine
 Cylinder number and layout:..... 4, vertical in line
 Displacement:..... 4485 cm³ - Aftercooler turbo compressor
 Cooling system:..... liquid



REFUELLING (litre)

Hydraulic system (total):..... 245
 Fuel tank:..... 126



STANDARD DEVICES

Hydraulic movements with proportional control distributor .
 Anti-tipping device with block for hazardous movements.
 Turret rotation 400°.
 Oscillation block on rear axle.
 Hydraulic socket for possible accessories on boom head.
 Closed soundproof FOPS approved driver's cab, with heating.
 Stabilizers.



TYRES













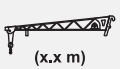
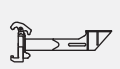

Tyres:..... 405/70x20"

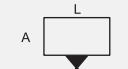

OPTIONALS AND ACCESSORIES

Optionals and Accessories:..... see the relevant catalogue.

SYMBOLS KEY

							
Extendable front Basket	Extendable three-sided basket	Jib (Measurements)	Jib (Measurements)	Continuous rotation	Front position	Stabilizers raised	Forks
							
Front fixed basket	Three-sided fixed basket	Winch (Capacity)	Fork-carrying plate hook	Non-continuous rotation	Do not work on tyres	Stabilizers lowered	DO NOT maneuver if the machine is NOT levelled

Equipment

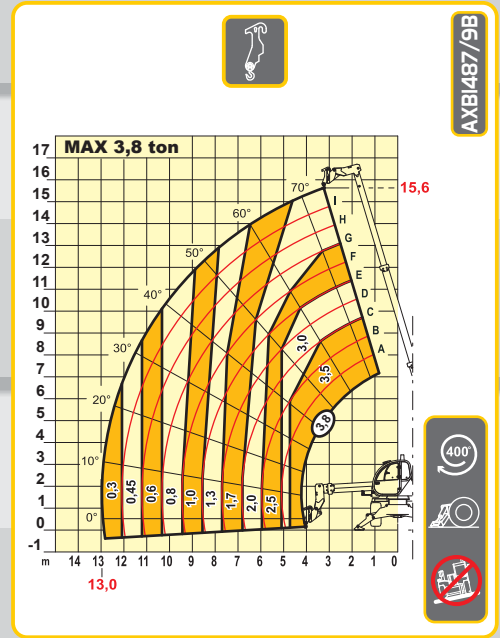
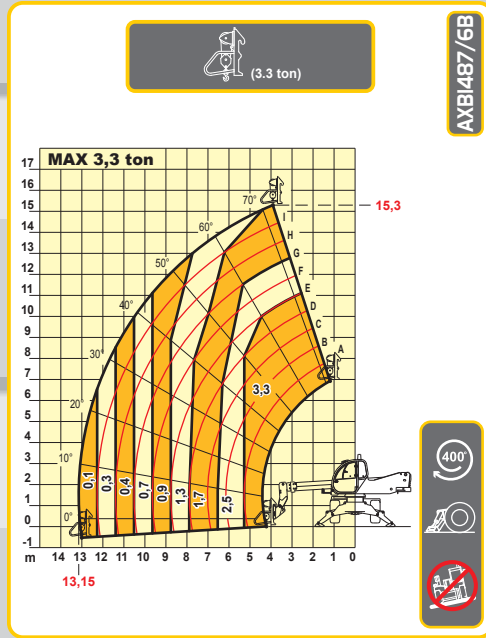
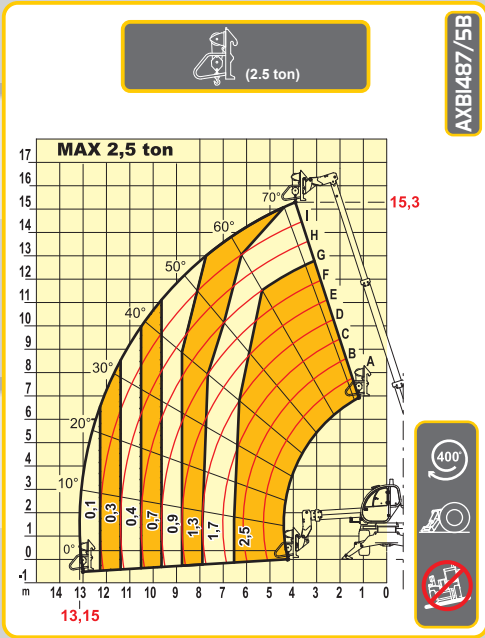
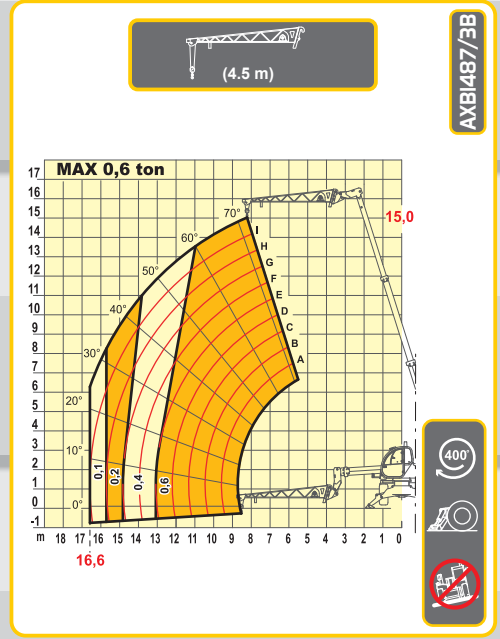
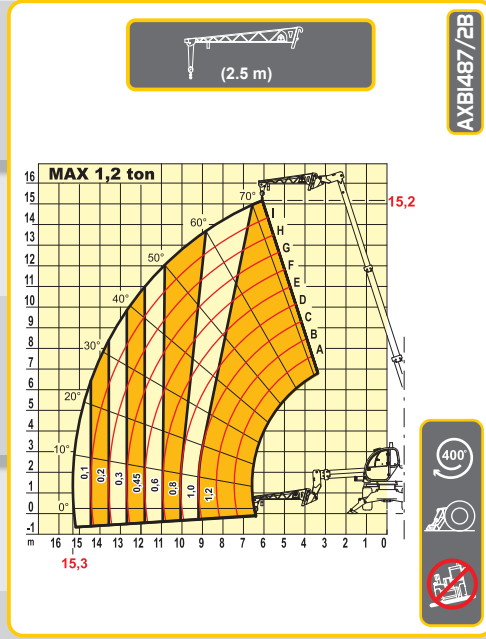
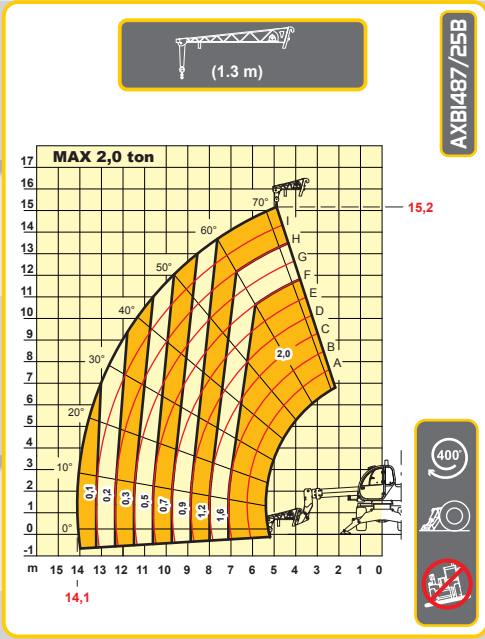
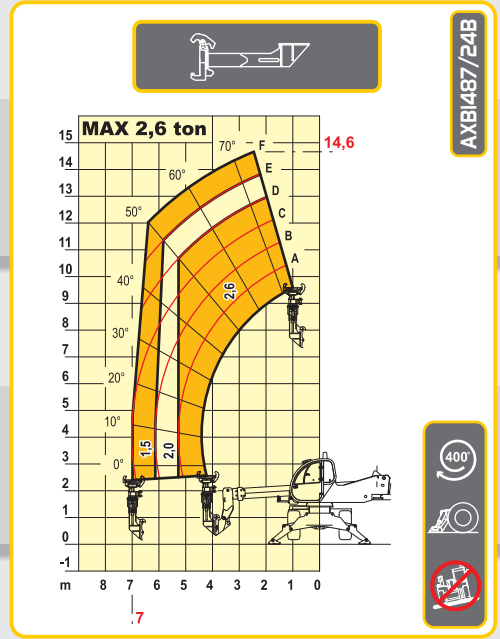
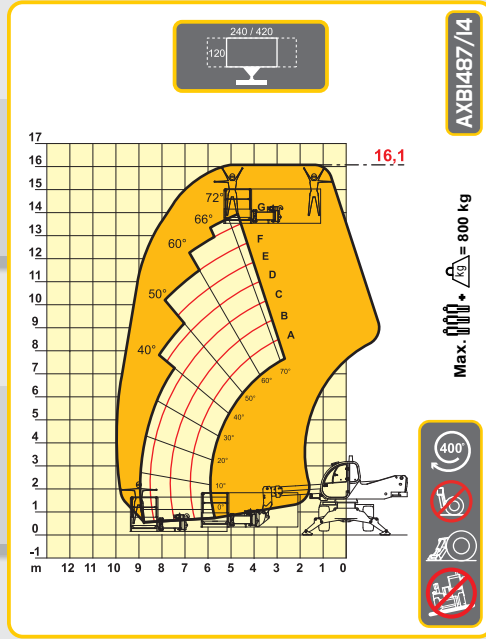
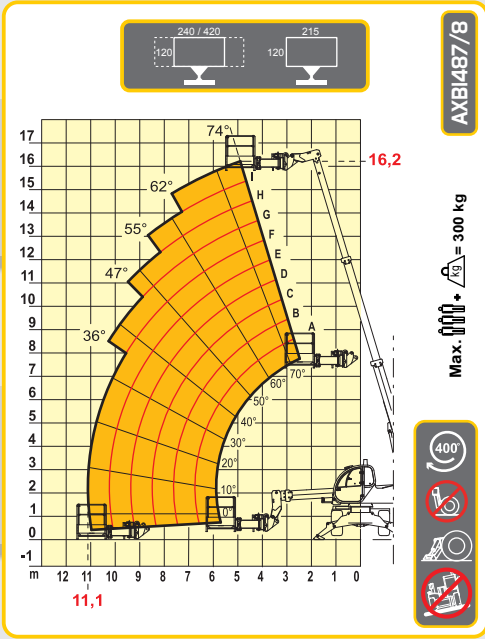

Pegasus 38.16

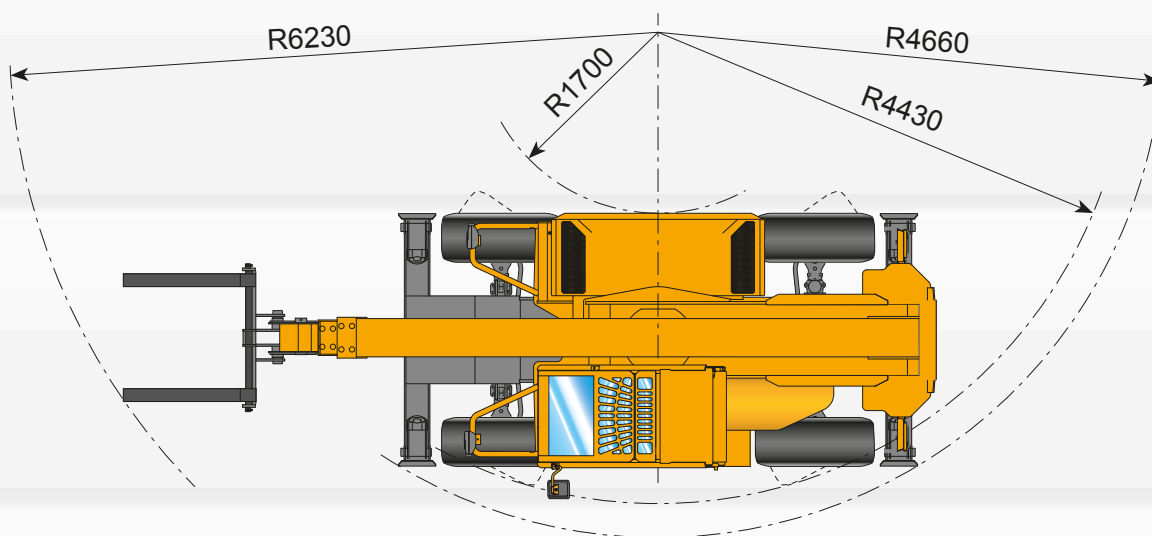
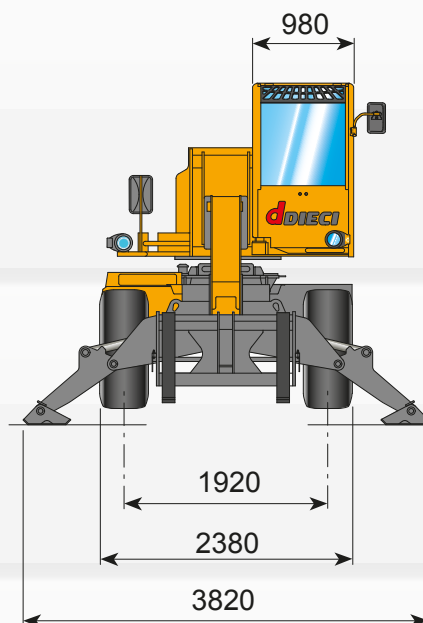
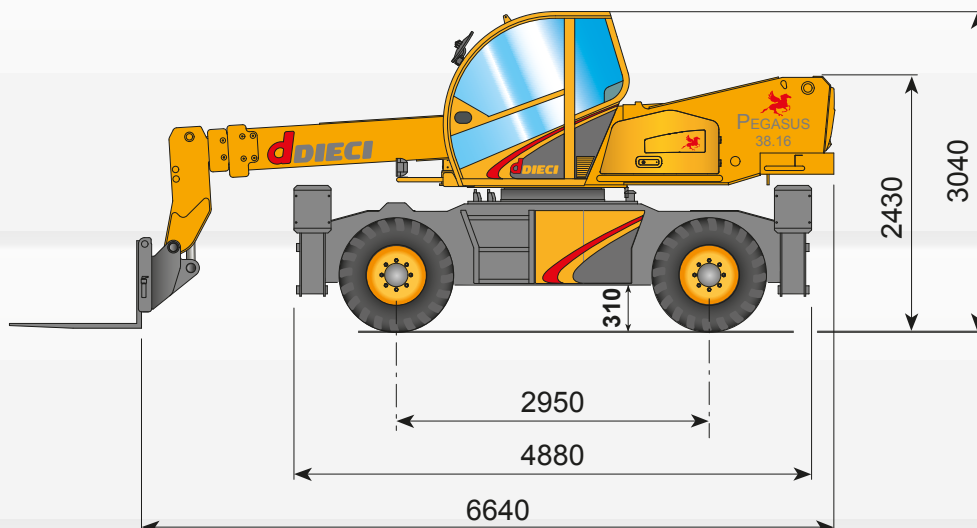

I dati contenuti in questo stampato sono forniti a titolo indicativo; i modelli descritti sono suscettibili di modifiche, senza preavviso, da parte del costruttore, disegni e fotografie possono riferirsi a equipaggiamenti opzionali o ad allestimenti destinati ad altri paesi. Per ogni altra informazione, rivolgersi alla sede DIECI all'indirizzo a fondo scheda.
 The information contained in the present publication is only intended as an indication; the models described may be modified, without notice, by the manufacturer, drawings and photographs may refer to optional equipment or to particular specifications for other countries. For any further information, please contact DIECI headquarters at the address given below.