



DRESSTA TD-25M LA

LANDFILL CRAWLER DOZER

EXTRA



■ **Net Horsepower**
246 kW (330 hp)

■ **Blade Capacity**
20.6 m³ (26.9 yd³)
25.5 m³ (33.4 yd³)

■ **Operating Weight**
42 010 kg (92,615 lb)
42 670 kg (94,070 lb)

TD-25M LA

LANDFILL CRAWLER DOZER



- Comfortable, sound suppressed cab
- Large capacity blades
- Two-speed geared steering
- Joystick for transmission and steering module control

ENGINE

- * Make and Model CUMMINS QSX15
- Type In-line, 6-cylinder
- Aspiration Turbocharged and CAC
- Fuel system HPI Electronic
- Gross Horsepower SAE J1995 280 kW (375 hp)
- ** Net Horsepower SAE J1349/ISO 9249 246 kW (330 hp)
- Rated rpm 1800 rpm
- Max. torque @1400 rpm 1825 Nm (1,346 lb-ft)
- Displacement 15 l (912 in³)
- Bore and Stroke 137 x 169 mm (5.39" x 6.65")
- Air cleaner dry type with exhaust aspirated primary, safety elements and service indicator

* Meets EU Stage IIIA and EPA Tier 3 emission regulations
 **Net Horsepower at the minimum speed of hydraulic fan 277 kW (370 hp)

TRANSMISSION & TORQUE CONVERTER

Modular, countershaft type power shift, electro-hydraulic control. Preset travel speed selection and auto-downshift. Single stage 415 mm (16") torque converter with a 2.45:1 stall ratio drives to transmission through a double universal joint.

TRAVEL SPEEDS

Gear	Range	Forward		Reverse	
		km/h	(mph)	km/h	(mph)
1 st	Low	3.0	(1.9)	3.7	(2.3)
	High	3.9	(2.4)	4.7	(2.9)
2 nd	Low	5.1	(3.2)	6.1	(3.8)
	High	6.6	(4.1)	7.9	(4.9)
3 rd	Low	8.0	(5.0)	9.6	(6.0)
	High	10.3	(6.4)	12.3	(7.6)

STEERING & BRAKING

Two-speed geared steering module provides gradual turns while maintaining full power to both tracks plus conventional clutch-brake performance for tight or pivot turns. This type of steering system offers superior traction in all types of operations and terrain. Coupled to 3-speed transmission, the 2-speed steering provides 6 speeds forward and 6 reverse. The left hand joystick controls transmission and steering drive for up and down shifting, steering, Hi/Lo selection and LH/RH gradual geared turn. Foot pedal applies both brakes for parking and downhill control. Brakes are spring applied and hydraulically released.

FINAL DRIVES

Double-reduction with planetary final drive stage provides desired gear reduction at the sprocket. Eight-piece bolt-on sprocket distributes wear evenly over track bushings letting every tooth ride free one-half of the time to reduce wear. Sprocket segments are replaceable without removing track frames.

TRACK FRAME

All-welded heavy box section track frame is kept in alignment with track frame guides providing true vertical oscillation.

- Track rollers, each side 7
- Top idlers, each side 2
- Front idlers (drum type) 1
- All rollers and idlers lifespan lubricated
- Oscillation at center of front idler 406 mm (16")

TRACKS

Lubricated Track System (LTS) virtually eliminates internal pin and bushing wear through use of a patented seal assembly. The split master link reduces chain removal and installation time.

- Track shoe width, standard 560 mm (22")
- Strutted track link pitch 250 mm (9.86")
- Track shoes, each side 38
- Ground contact area 3.5 m² (5,456 in²)
- Ground pressure (w/std. equipment) 117 kPa (17 psi)
- Height of grouser 76 mm (3")
- Track adjustment full hydraulic
- Ground clearance 575 mm (22.6")

REFILL CAPACITIES

	Liter	(US gal)
Fuel tank	825	(218)
Cooling system	56	(15)
Crankcase	49	(13)
Transmission system	240	(63)
Final drive, each side	64	(16.9)
Hydraulic reservoir	130	(34)

OPERATING WEIGHT

Includes std. equipment, blade equipment, coolant, lubricants and full fuel tank:

- Semi-U dozer 42 010 kg (92,615 lb)
- Full-U dozer 42 670 kg (94,070 lb)

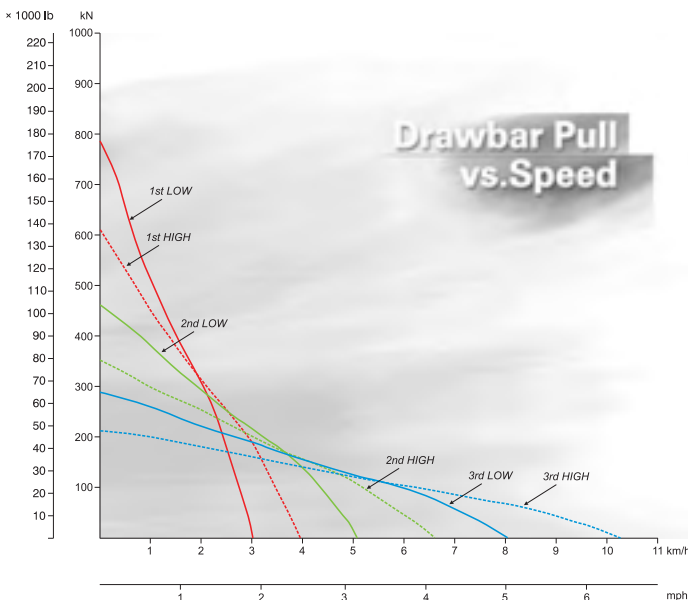

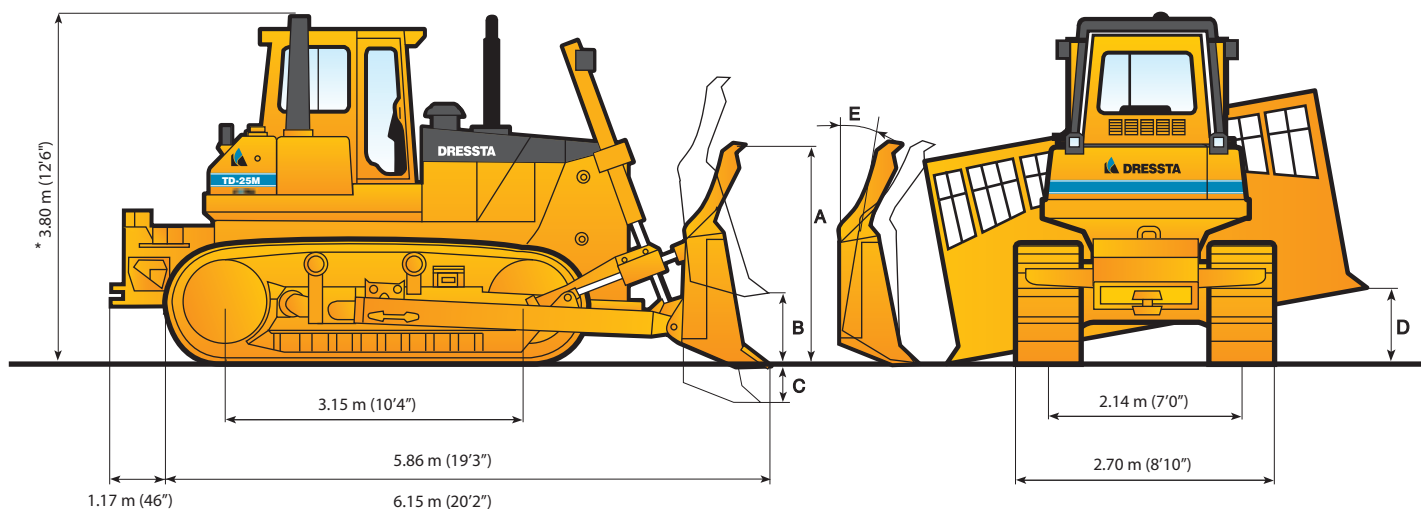

* DIMENSION INCLUDES 76 mm (3") GROUSER HEIGHT

OVERALL DIMENSIONS WITH EQUIPMENT

BLADE SELECTION	SEMI-U	FULL-U
Length with blade and rear striker bars	7.03 m (23'1")	7.32 m (24')
Length with blade and multi-shank ripper	8.38 m (27'6")	8.65 m (28'5")
Length with blade and single shank ripper	8.94 m (29'4")	9.21 m (30'3")
Width over trunnions	3.21 m (10'6")	3.21 m (10'6")

BLADE SPECIFICATIONS

BLADE SELECTION		SEMI-U	FULL-U
Blade Capacity, SAE J1265		20.6 m ³ (26.9 yd ³)	25.5 m ³ (33.4 yd ³)
Blade Dimensions: – width over end bits		4.05 m (159.4")	4.36 m (171.3")
– height, struts centered	A	2.50 m (98.2")	2.56 m (100.9")
Max. lift, straight	B	1.27 m (50")	1.27 m (50")
Max. drop below ground level	C	600 mm (23.6")	600 mm (23.6")
Max. tilt adjustment	D	880 mm (34.6")	945 mm (37.2")
Max. pitch adjustment	E	10°	10°
Weight of blade equipment		7310 kg (16,116 lb)	7970 kg (17,570 lb)

RIPPER SPECIFICATIONS

RIPPER SELECTION	MULTI-SHANK	SINGLE-SHANK	
		Standard	Deep
Tool Beam			
Overall width	2 485 mm (98")	1 450 mm (57")	1 450 mm (57")
Cross section (height x width)	380 x 478 mm (15" x 18.8")	400 x 550 mm (15.7" x 21.7")	400 x 550 mm (15.7" x 21.7")
Ground clearance under tool beam: - ripper raised	1 544 mm (68")	1 565 mm (62")	1 565 mm (62")
- ripper lowered	171 mm (6.7")	154 mm (6.1")	154 mm (6.1")
Shanks			
Number of shanks per ripper, max.	3	1	1
Spacing center to center	1 067 mm (42")	–	–
Penetration, max.	760 mm (29.9")	1 250 mm (49.2")	1 700 mm (66.9")
Ground clearance, max. raised	868 mm (34.2")	770 mm (30.3")	760 mm (29.9")
Shank positions (vertical)	2	4	6
Weight			
Complete, including one shank	5 100 kg (11,270 lb)	5 280 kg (11,630 lb)	5 370 kg (11,840 lb)
Each additional shank	318 kg (700 lb)	–	–
Penetration Force	131.2 kN (29,494 lb)	132.5 kN (29,786 lb)	132.5 kN (29,786 lb)
Pryout Force	353.5 kN (79,467 lb)	377.7 kN (84,907 lb)	377.7 kN (84,907 lb)

TD-25M LA

LANDFILL CRAWLER DOZER



HYDRAULIC CONTROL SYSTEM

Multiple vane pumps, driven from torque converter.

Output @ 2146 rpm:

1 st pump	178 l/min (47 gpm) @ 15.5 MPa (2,248 psi)
2 nd pump	102.2 l/min (27 gpm) @ 16.9 MPa (2,450 psi)
and pilot pump	33.3 l/min (8.8 gpm) @ 2.0 MPa (290 psi)

Relief valve setting:

blade lift & ripper	17.2 MPa (2,500 psi)
tilt	18.4 MPa (2,670 psi)
Cylinders, bore and stroke:	
blade lift	127 x 1460 mm (5.0" x 57.5")
tilt	200 x 130 mm (7.9" x 5.1")
tilt/pitch	185/200 x 130 mm (7.3"/7.9" x 5.1")

STANDARD EQUIPMENT

- Air cleaner, dry type, with exhaust aspirated primary, safety elements and service indicator. Includes turbine type pre-cleaner with debris guard
- Air conditioner/heater/pressurizer/defroster, underseat mounted; A/C condenser, behind roof mounted
- Alarm, back-up
- Alternator, 100A
- Antifreeze, -37°C (-34°F)
- Batteries, (4) 12 V, 1920 CCA, maintenance free, cold start
- Brakes, foot, spring applied, hydraulically released
- Coolant filter conditioner
- Cab with 2 post ROPS, sound suppression, air recirculation system, 2 F & 2 R lights, 4 wipers w/washers, dome light, inside mirror (approved according to ROPS - SAE J1040 and FOPS - SAE J231)
- Cooling module; includes radiator, transmission oil cooler, fuel cooler, hydraulic oil/fan drive oil cooler, charge air cooler; isolation mounted
- Cylinders, lift, with quick drop valve
- Decelerator - right foot pedal and brake - center foot pedal
- Diagnostic centers for power train and equipment hydraulic pressures
- Ecological drains for engine oil, radiator coolant and hydraulic oil
- Engine hood, sloped, perforated type
- Engine side doors, hinged, perforated type
- Exhaust, resonator with elbow
- Fan, hydraulically driven, in-motion variable blade pitch system, airflow reversible
- Filters, engine oil, full flow and by-pass with replaceable "spin-on" elements
- Filters, power train & equipment hydraulics, "spin-on" micro glass type
- Final drive seal guard
- Fuel strainer
- Guards: crankcase, hinged, serve service type with front pull hook, transmission, severe service type, fan, radiator, sprocket rock and dirt deflector
- Horn, electric
- Hydraulic control, 1 valve, 1 lever with pilot operated blade control (lift)
- Instruments:
 - Gauges: fuel level, engine coolant temperature, engine oil pressure, torque converter oil temp., voltmeter, hourmeter, joystick control display
 - Warning lights: air cleaner filter, transmission oil filter, hydraulic oil filter, transmission/clutch oil low pressure, reversed air flow
 - Audible & visual warning system: low engine coolant level, low engine oil pressure, high engine coolant temp., high torque converter oil temp.
- Lights with guards, 2 F - lift cylinders mounted, 2 R with metal grid covers - fuel tank mounted
- Muffler, under engine hood, insulated
- Portable lamp receptacle
- Radiator guard doors, louvered, two-piece, hinged, quick opening
- Rear access platform
- Receptacle, charging
- Seat belt (SAE J386) - 3" wide, retractable
- Seat, deluxe, air suspension type, fabric cover, adjustable with arm rests, swivel 14° to right
- Special rear, quick opening, perforated type enclosure plates beneath fuel tank
- Starting, 24 V
- Starting aid - air grid heater
- Steel debris deflector bars, below engine side doors
- Steering, planetary type, 2 speed, left hand single lever control (joystick)
- Striker bars, front
- Striker bars, rear. Include rigid drawbar and counterweight (storage space for 6 vertical plates), include 3 plates
- Tools compartment
- Torque converter, single stage
- Track adjusters, hydraulic
- Track chain, sealed and lubricated (LTS) with split master link, 38 links
- Track chain guides, integral
- Track frame, 7 roller, 2140 mm (84") gauge, oscillating type, lifespan lubricated rollers and idlers
- Track shoes 560 mm (22"), grouser type with clean out holes
- Transmission, power shift, 3 speeds forward, 3 reverse, combined with 2 speed steering provides 6 speeds forward and 6 reverse; preset travel speed selection and auto-downshift
- Vandalism protection for cab & engine enclosures
- Water separator, fuel system
- Winch, electrical, for lowering engine crankcase guard

OPTIONAL ATTACHMENTS

- Air recirculation system with MSHA filters
- AM/FM CD radio
- Blade Equipment:
 - Full-U, with trash rack, 25.5 cu.m (33.4 cu.yd), includes hydraulic tilt (additional counterweight must be ordered)
 - Semi-U, with trash rack, 20.6 cu.m (26.9 cu.yd), includes hydraulic tilt
 - Hydraulic tilt/pitch for Semi-U or Full-U dozer
- Guards:
 - Final drive rock
 - Fuel tank and hydraulic reservoir
 - Track roller, full length
 - Additional counterweight, 3 plates (for use with standard rear striker bars)
- Hydraulic controls, 3-spool valve, 2 lever (for use w/ripper)
- Inspection lamp, 24 V, portable with 6 m (20') cable
- Lights, 2 F, ROPS mounted
- Mirrors, 2 pcs, exterior
- Ripper, multi-shank w/hydraulic pitch
 - Rear striker bars, ripper frame mtd
 - Ripper shank w/pin, max. 3
- Ripper, single-shank w/hydraulic pitch
 - Rear striker bars, ripper frame mtd
 - Ripper shank, standard dig
- Ripper shank, deep dig
- Pin puller, hydraulic
- Screening pkg; cab for screens installation must be ordered:
 - Screens for cab windows (front, rear, side and doors)
 - Screens for cab lights
- Starting/charging receptacle plug assembly with 4.6 m (15') cable
- Sun visor in cab
- Tools in metal box
- Track shoes, type with clean out holes: 610 mm (24"), 660 mm (26"), 711 mm (28")

Specifications subject to change without notice. Illustrations and pictures may include optional equipment and may not include all standard equipment.

DRESSTA Co.Ltd.

Kwiatkowskiego 1, 37-450 Stalowa Wola, POLAND
 tel. +48 (15) 813 5252, 813 4556 fax: +48 (15) 844 4714
www.dressta.com.pl