



Agri Farmer



26.6



28.7



30.7



28.9



30.9

PERFORMANCE

	26.6	28.7	30.7	28.9	30.9
Maximum capacity (kg)	2.600	2.800	3.000	2.800	3.000
Maximum lifting height (m)	5,95	6,35	6,35	8,70	8,70
Maximum horizontal outreach (m)	3,35	3,65	3,65	5,70	5,70
Outreach at maximum height (m)	0,66	0,80	0,80	0,80	0,80
Fork swivelling angle	134°	130°	130°	130°	130°
Pull-out force (daN)	5.700	5.700	5.700	5.700	5.700
Towing force (daN)	7.300	7.300	7.300	7.300	7.300
Maximum climb angle	40%	40%	40%	40%	40%
Total weight empty (kg)	5.900	6.100	6.100	6.250	6.250
Max speed (km/h) (referred to wheels having the maximum allowable diameter)	35	35	35	35	35

BOOM

	26.6	28.7	30.7	28.9	30.9
Times: (in seconds)					
Lifting	7,6	9,5	9,5	10,3	10,3
Descent	3,9	4,9	4,9	5,3	5,3
Extension	6,2	7,2	7,2	9,5	9,5
Retraction	3,4	4,0	4,0	6,6	6,6
Forward swivelling	3,2	4,1	4,1	4,1	4,1
Reverse swivelling	2,0	2,6	2,6	2,6	2,6

Patented compensation system

ENGINE

Model:	Perkins
Maximum power kW (hp):	74.5 (101)
Revolutions per minute (rpm):	2200
Operation:	4 stroke diesel
Injection:	Direct mechanical
Number and arrangement of cylinders:	4, vertical in line
Engine size (cm ³):	4400
Specific consumption at 2200 rpm (g/kWh):	251
	Turbo compressor
	Liquid cooling system

OPTIONALS AND ACCESSORIES

A/C; Webasto Heater; Digital speedometer; Water Heater; Driver's seat with pneumatic suspension; Light on boom head; Quick coupling for accessories; Radio; Anti-theft system; Glass protection.

(For additional customizations, contact the area dealer)

TRANSMISSION

Hydrostatic transmission with variable displacement pump.

Hydrostatic engine with automatic variation.

Electrical - hydraulic inversion.

Inching pedal for controlled advancement.

Servocontrolled 2-speed gearbox.

HYDRAULIC PLANT

Gear pump with capacity at max. speed (lt/1'):	110
Max operational pressure (bar):	230
Distributor control with joystick:	3 in 1

DIFFERENTIAL AXLES

Steering axles: 2, with planetary reduction gears
Steering types: 4 wheels / transversal / 2 wheels
Front axle: rigid
Back axle: oscillating
Oil bath service braking on the front axle
Negative action parking brake.

REFUELLING (Litres)

Hydraulic plant (total)	130
Fuel tank	100

DEVICES AS PER STANDARD

Anti-tipping device with peyorative movement block.

Hydraulic socket for any accessories on the boom head.

Soundproof closed cab, ROPS-FOPS approved, with heater.

Self-blocking front axle differential (limited slip 45%).

Self-cleaning filter with cyclone filters.

Electric window winder.

TOWING CAPACITY (upon request)

Trailer without brakes (ton):	3
Mechanical braking (ton):	5
Hydraulic/pneumatic braking (ton):	17
Including 20" wheels	

TYRES

	26.6	28.7 28.9	30.7 30.9
Tyres	12,5x18"	12,5x18"	405/70x20"
(*) Alternative	405/70x20"	405/70x20"	405/70x24"
(**) Alternative	405/70x24"	405/70x24"	

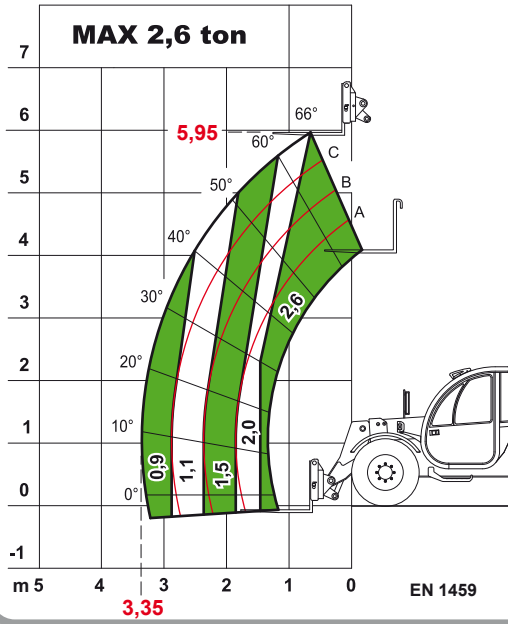

Agri Farmer 26.6

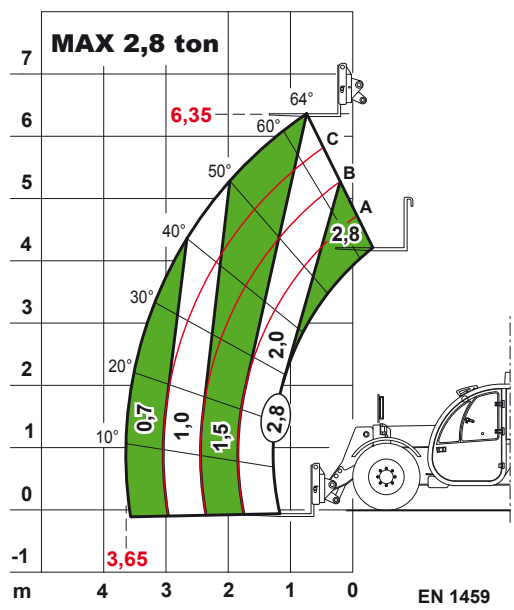

Agri Farmer 28.7

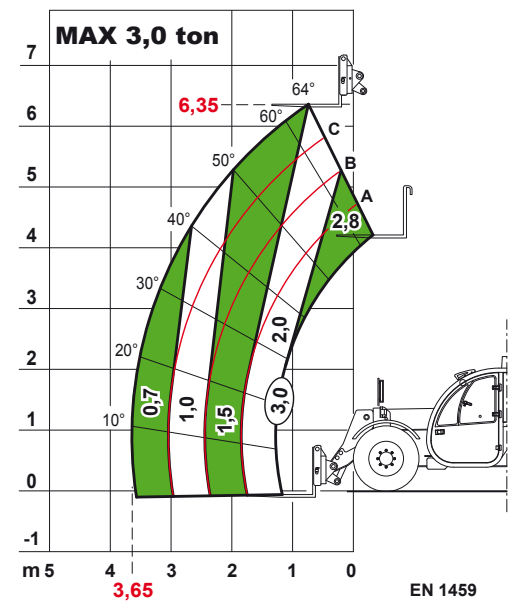

Agri Farmer 30.7

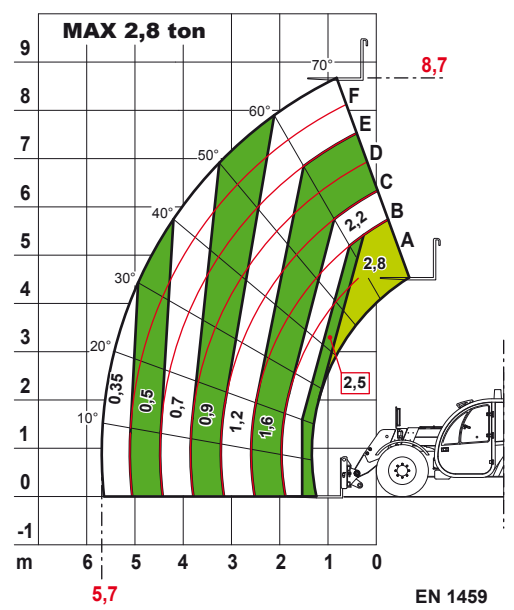

Agri Farmer 28.9

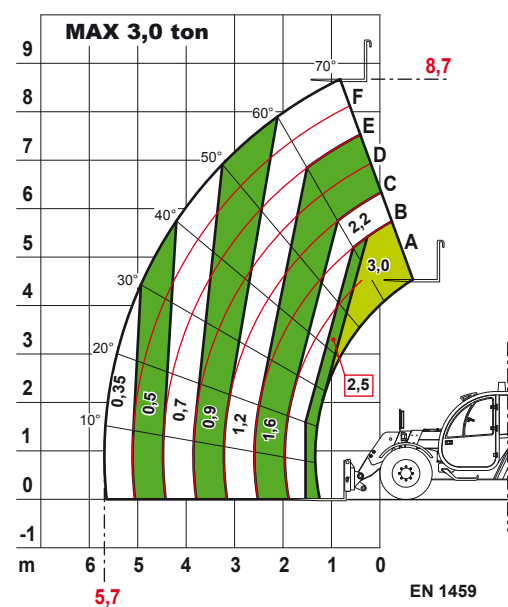

Agri Farmer 30.9

Accessories and Attachments specific for any need

Fork with three jointed prongs



Bucket with teeth

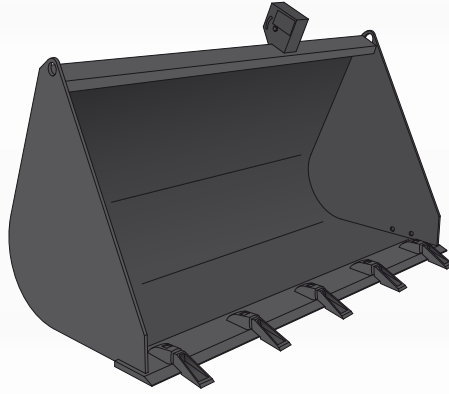

Clamp for logs

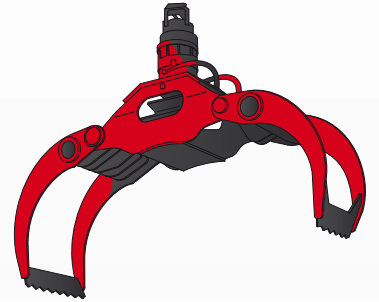

Bucket with holder

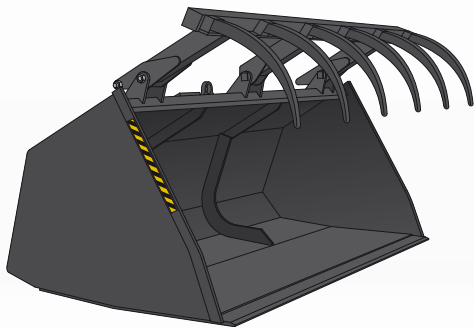

Bucket for silage

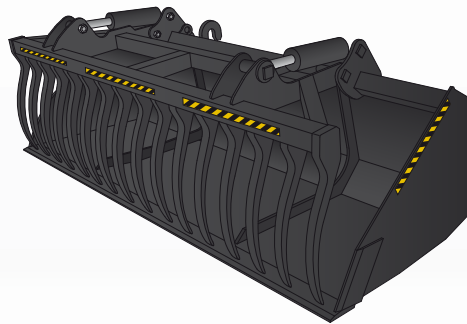

Boom suspension



Clamp for big wrapped bales

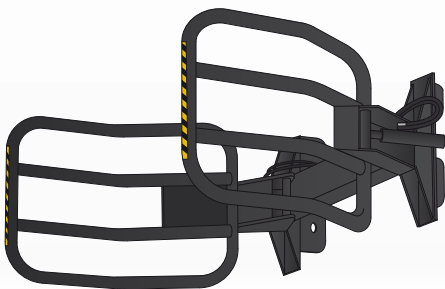

Aluminium man basket

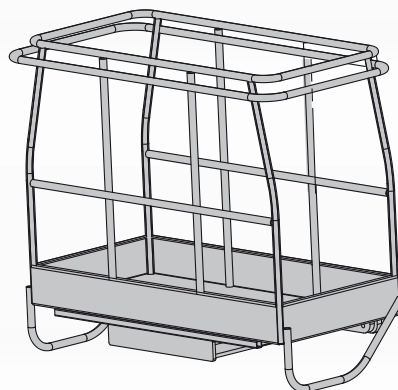

Without the requirement for full tyres or outriggers

Clamp for two roll bales



This is only a part of the many accessories and various equipment available for Dieci machines.
For information about the entire range of accessories **CONTACT US** using contact information contained on the rear of the document.



360° Visibility

From the significantly raised driver's seat, the innovative anti-fall protection system, located inside the cab, allows for a 360° view that is without comparison.

Two independent rear-view mirrors on both sides reduce blind spots to a minimum.



Comfort

A telescopic lift that takes care of everything... You will notice it immediately, equipped with the largest door on the market, accessing the driver's seat will no longer be a problem. The inside of the cab has been entirely designed in order to make work easier for the operator. Thanks to the integration of the armrest in the right instrument panel, it both reduces arm stress and provides greater accessibility to the joystick. The precise distribution of the ventilation grills optimises efficiency of the heating and air conditioning system, providing a perfect distribution of air inside of the cab.



Engine: low consumption, high yield

Designed for intense use, they guarantee a high level of reliability over time. The new TIER III engines guarantee remarkable elasticity providing maximum power, even at low engine speed and an unparalleled low operational noise level.

This, along with the possibility of equipping the machine with a particle filter, provides for drastic reduction of consumption.



Safety

For us, safety is an absolute priority, it is guaranteed by an electronic system, standard on all models, which makes it possible to always keep the weight on the forks or on equipment under control during work manoeuvres.

The load limiter flexibly and accurately manages both standard equipment and that used for specific applications.



Design

Dieci has always considered design a significant aspect when engineering their own products.

This philosophy is evident when considering the newly designed cab and chassis restyling.

Paying particular attention, Dieci engineers have been able to interpret the request of a comfortable and functional compartment, creating a spacious and ergonomic cab with snappy styling.



Great agility and reduced steering radius

One of the characteristics that distinguish Dieci telescopic devices the most is workability. The extremely reduced steering radius combined with high capacity axles make the machine both agile and powerful. The four drive wheels and the possibility of steering the wheels in three different modes, make it possible to operate on any type of land. Muddy ground, mountain areas, tight spaces and many other extreme conditions will no longer be an obstacle.

DIMENSIONS

	26.6	28.7	30.7	28.9	30.9
A/A*/A**	360/400*/440**	360/400*/440**	400/440*	360/400*/440**	400/440*
B	1195	1210	1210	1267	1267
C	2550	2800	2800	2800	2800
D	750	650	650	747	747
E/E*/E**	3790/3840*/3890**	3940/3990*/4040**	3990/4040*	4037/4087*/4137**	4087/4137*
F	4490	4670	4670	4720	4720
G	940	940	940	940	940
H/H*/H**	2200/2240*/2280**	2000/2040*/2080**	2220/2260*	2000/2040*/2080**	2220/2260*
I	1600	1600	1600	1600	1600
L	2000	2000	2000	2000	2000
M	4800	4900	4900	4900	4900
N	1530	1670	1670	1670	1670
O	3840	4000	4000	4000	4000

Measurements expressed in millimetres

(*) - (**) = Measurements referring to optional wheels

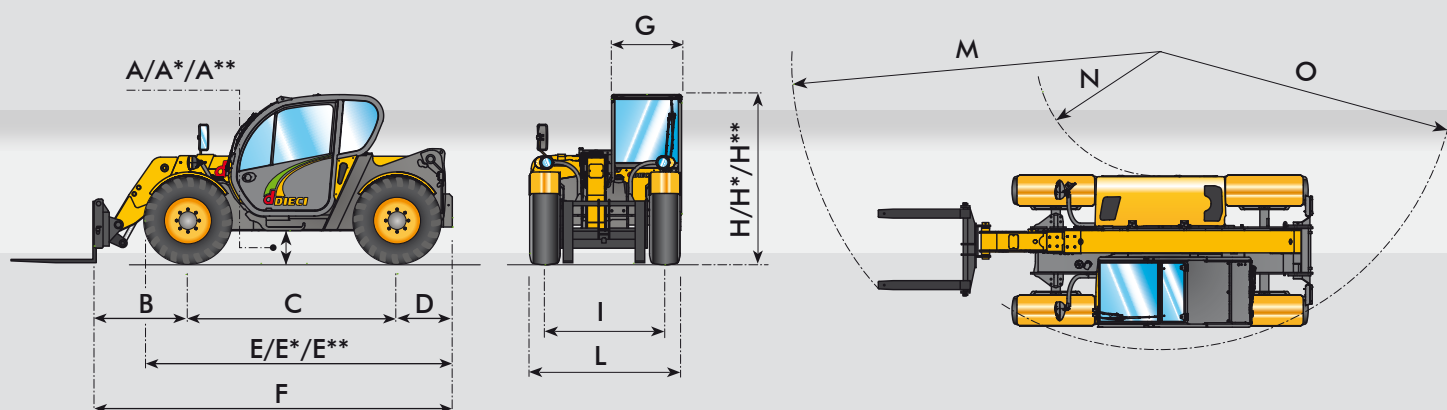

(*) - (**) = Measurements referring to optional wheels



macchine edili ed agricole
dIECI

Via E. Majorana, 2-4 42027 Montecchio Emilia (RE) ITALY

Tel. +39 0522 869611 Fax +39 0522 869791 (comm. le Estero) Fax +39 0522 869604 (comm.le Italia)

www.dieci.com - E-mail: info@dieci.com